

TECHNICAL MANUAL

OPERATOR'S, UNIT AND DIRECT
SUPPORT MAINTENANCE MANUAL
FOR

40,000 GALLON WATER
DISTRIBUTION SYSTEM
NSN 4610-01-114-1451

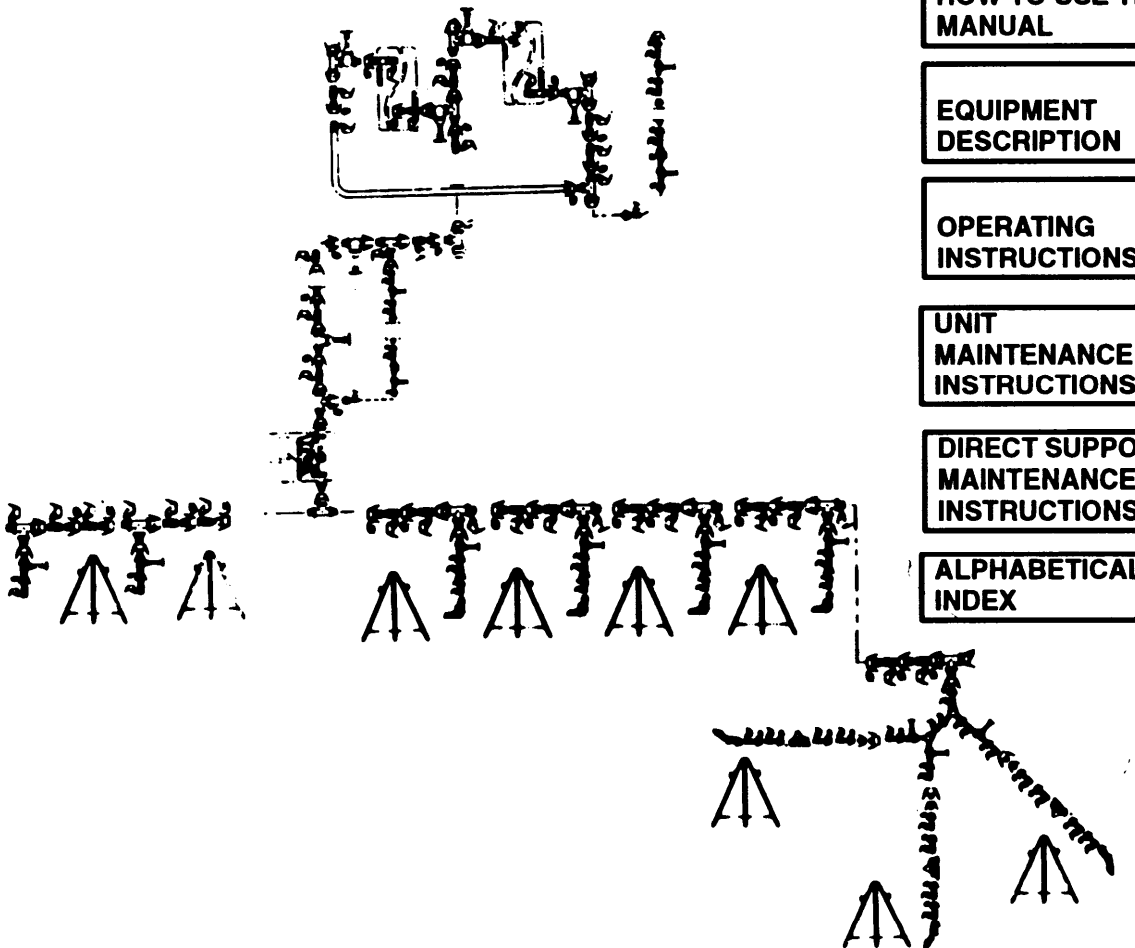

HOW TO USE THIS MANUAL	iii
EQUIPMENT DESCRIPTION	1-3
OPERATING INSTRUCTIONS	2-1
UNIT MAINTENANCE INSTRUCTIONS	4-1
DIRECT SUPPORT MAINTENANCE INSTRUCTIONS	5-1
ALPHABETICAL INDEX	Index-1

DISTRIBUTION STATEMENT A: Approved for public release; distribution is unlimited

* This manual supersedes TM 5-4610-234-13, dated 10 August 1990.

HEADQUARTERS, DEPARTMENT OF THE ARMY

30 JUNE 1993

CHANGE

No. 2

HEADQUARTERS
DEPARTMENT OF THE ARMY,
WASHINGTON, D.C., 30 July 1995

Operator's, Unit, and Direct
Support Maintenance Manual

**40,000 GALLON WATER STORAGE AND DISTRIBUTION SYSTEM
MODEL WSDS40K
NSN 4610-01-114-1451
MODEL 40KWSDS
NSN 4610-01-382-3583
MODEL ALP9440
NSN 4610-01-413-1886**

DISTRIBUTION STATEMENT A: Approved for public release; distribution is unlimited

TM 10-4610-234-13, 30 June 1993, is changed as follows:

1. Title is changed as shown above.
2. Remove and insert pages as indicated below. New or changed text material is indicated by a vertical bar in the margin. An illustration change is indicated by a miniature pointing hand.

Remove pages
i and ii
4-15 through 4-18

4-37 through 4-40

Index-1 through Index-4

Insert pages
i and ii
4-15 through 4-18
4-18.1 through 4-18.4
4-37 through 4-40
4-40.1 and 4-40.2
Index-1 through Index-4

3. Retain this sheet in front of manual for reference purposes.

By Order of the Secretary of the Army:

Official:



JOEL B. HUDSON

*Acting Administrative Assistant to the
Secretary of the Army*

00536

DENNIS J. REIMER
General, United States Army
Chief of Staff

DISTRIBUTION:

To be distributed in accordance with DA Form 12-25-E, block no. 6064, requirements for
TM 10-4610-234-13.

CHANGE
NO. 1

HEADQUARTERS
DEPARTMENT OF THE ARMY
WASHINGTON, D.C., 29 APRIL 1994

Operator's, Unit and Direct Support
Maintenance Manual
for
40,000 GALLON WATER STORAGE AND DISTRIBUTION SYSTEM
MODEL WSDS40K
NSN: 4610-01-114-1451 AND
MODEL 40KWSDS
NSN: 4610-01-382-3583

DISTRIBUTION STATEMENT A: Approved for public release; distribution is unlimited.

TM 10-4610-234-13, 30 June 1993, is changed as follows:

1. Title is changed as indicated above.
2. Remove and insert pages as indicated below. New or changed text material is indicated by a vertical bar in the margin. An illustration change is indicated by a miniature pointing hand.

Remove pages

i and ii
1-1 and 1-2
4-9 and 4-10
4-31 through 4-36

Index-1 through Index-4

Insert pages

i and ii
1-1 and 1-2
4-9 and 4-10
4-31 through 4-36
4-36.1 through 4-36.4
Index-1 through Index-4

3. Retain this sheet in front of manual for reference purposes.

By Order of the Secretary of the Army:

GORDON R. SULLIVAN
General United States Army
Chief of Staff

Official:

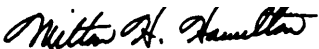
MILTON H. HAMILTON

Administrative Assistant to the
Secretary of the Army
06781

DISTRIBUTION:

To be distributed in accordance with DA Form 12-25-E, block no. 6064, requirements for TM 10-4610-234-13.

Warning

Do not open hose couplings when water system is under pressure. Hose end can whip, causing injury to personnel and damage to equipment.

To prevent contamination of drinking water, make sure water tank elbows are capped and plugged when system hoses are not connected to tank.

To prevent contamination of drinking water, make sure caps and plugs are installed when components are not in use.

To prevent contamination of drinking water, keep dirt, mud, sand and debris from entering open couplings during assembly and disassembly.

Hoist used to lift water tanks from water tank chests must have minimum lifting capacity of 750 pounds.

For artificial respiration, refer to FM 21-11.

TECHNICAL MANUAL
NO. 10-4610-234-13

HEADQUARTERS
DEPARTMENT OF THE ARMY
WASHINGTON, D.C., 30 June 1993

TECHNICAL MANUAL

Operator's Unit and Direct Support
Maintenance Manual
for
40,000 Gallon Water Storage and Distribution System
MODEL WSDS40K
NSN: 4610-01-114-1451
MODEL 40KWSDS
NSN: 4610-01-382-3583
MODEL ALP9440
NSN: 4610-01-413-1886

REPORTING ERRORS AND RECOMMENDING IMPROVEMENTS

You can help improve this manual. If you find any mistakes, or if you know of a way to improve these procedures, please let us know. Mail your letter or DA Form 2028 (Recommended Changes to Publications and Blank Forms), or DA Form 2028-2 located in the back of this manual directly to: Commander, US Army Aviation and Troop Command, ATTN: AMSAT-I-MP, 4300 Goodfellow Blvd., St. Louis, MO 63120-1798. You may also submit your recommended changes by E-mail directly to <daf2028@st-louis-emh7.army.mil>. A reply will be furnished directly to you.

DISTRIBUTION STATEMENT A: Approved for public release; distribution is unlimited

TABLE OF CONTENTS

		PAGE
	HOW TO USE THIS MANUAL	iii
CHAPTER 1	INTRODUCTION	
Section I	General Information	1-1
Section II	Equipment Description	1-3
Section III	Technical Principles of Operation	1-6
CHAPTER 2	OPERATING INSTRUCTIONS	
Section I	Description and Use of Operator's Controls and Indicators	2-1
Section II	Operator's Preventive Maintenance Checks and Services (PMCS)	2-5
Section III	Operation Under Usual Conditions	2-17
Section IV	Operation Under Unusual Conditions	2-40
CHAPTER 3	OPERATOR MAINTENANCE	
Section I	Lubrication Instructions	3-1

* This manual supersedes TM 10-5-4610-234-13, dated 10 August 1990.

TABLE OF CONTENTS - continued

	PAGE
Section II Operator Troubleshooting Procedures	3-1
Section III Operator Maintenance Procedures	3-4
CHAPTER 4 UNIT MAINTENANCE	
Section I Repair Parts, Special Tools; Test, Measurement and Diagnostic Equipment (TMDE); and Support Equipment	4-1
Section II Service Upon Receipt	4-1
Section III Unit Preventive Maintenance Checks and Services	4-5
Section IV Unit Troubleshooting Procedures	4-7
Section V Unit Maintenance Procedures	4-9
Section VI Preparation for Storage and Shipment	4-53
CHAPTER 5 DIRECT SUPPORT MAINTENANCE INSTRUCTIONS	
Section I Direct Support Maintenance Procedures	5-1
Appendix A References	A-1
Appendix B Maintenance Allocation Chart....	B-1
Appendix C Components of End Item and Basic Issue Items List	C-1
Appendix D Expendable/Durable Supplies and Materials List	D-1
Appendix E Additional Authorization List (AAL).	E-1
Index	Index-1

HOW TO USE THIS MANUAL

Be sure to read all Warnings before using your equipment.

This manual contains operating instructions and Operator, Unit and Direct Support Maintenance instructions for the 40K Water Distribution System.

- Chapter 1- Introduces you to the equipment and gives you information such as weight, height, length, generally used abbreviations, cross reference information and principles of operation. The chapter is preceded by a full page illustration of the equipment.

- Chapter 2- Provides information necessary to identify and use the equipment's operating controls. Operating procedures tell you how to use the equipment in both usual and unusual weather conditions. In addition, preventive maintenance instructions provide information needed to inspect and service the water system.

- Chapter 3- Provides operator maintenance instructions for troubleshooting equipment malfunctions.

- Chapter 4- Provides unit maintenance instructions including service upon receipt, preventive maintenance and troubleshooting information; detailed maintenance and repair procedures for the Unit Maintenance repairer and storage and shipment instructions.

- Chapter 5- Provides detailed component repair instructions for the Direct Support maintenance group.

- Appendix A gives you a list of frequently used forms and publications.

- Appendix B is the Maintenance Allocation Chart (MAC).

- Appendix C describes components that make up the end item and are shipped with the basic equipment. It also lists components that are not mounted on the equipment, but are required to make the system functional. All components in the Components of End Item and Basic Issue Items Lists are illustrated for easy identification.

- Appendix D provides you with information about expendable supplies such as sealant, paint, lubricants, etc.

- Appendix E lists additional equipment authorized for your unit for use with the water system, but are not supplied as part of system. This equipment list may include fire extinguishers, buckets, protective clothing etc.

- The Alphabetical Index is the last item in the TM. You will find it useful in locating page numbers about specific information or procedures. Becoming familiar with this manual will enable you to operate and maintain the equipment in good working order.

CHAPTER 1 INTRODUCTION

Section I. GENERAL INFORMATION

1.1 SCOPE.

- a. Type of Manual. This is an Operators, Unit, and Direct Support Maintenance manual for use with two similar 40K Water Storage and Distribution Systems (WSDS). It provides instructions for operating and maintaining the equipment.
- b. Model Number and Equipment Name. The nomenclature is Water Storage and Distribution System, Model WSDS40K or Model 40KWSDS. The components of these systems are interchangeable.
- c. Purpose of Equipment. Stores and distributes potable water.

1.2 MAINTENANCE FORMS AND RECORDS.

Department of the Army forms and procedures used for equipment maintenance will be those prescribed by DA PAM 738-750, The Army Maintenance Management System (TAMMS).

1.3 DESTRUCTION OF ARMY MATERIEL TO PREVENT ENEMY USE

For procedures and materials used to destroy Army materiel to prevent enemy use, refer to TM 750-244-3.

1.4 REPORTING EQUIPMENT IMPROVEMENT RECOMMENDATIONS (EIR'S).

If your Water Storage and Distribution System needs improvement, let us know. Send us an EIR. You, the user, are the only one who can tell us what you don't like about your equipment. Let us know why you don't like the design or performance. Put it on an SF 368 (Quality Deficiency Report). Mail it to us at Commander, US Army Aviation and Troop Command, ATTN: AMSAT-I-MDO, 4300 Goodfellow Blvd., St. Louis, MO 63120-1798.

1.5 PREPARATION FOR STORAGE OR SHIPMENT.

- a. Placement of equipment in administrative storage should be for short periods of time when shortage of maintenance efforts exist. Items should be in mission readiness within 24 hours or within the time factors as determined by the directing authority. During the storage period, appropriate maintenance records will be kept.
- b. Before placing equipment in administrative storage, current preventive maintenance checks and services evaluations should be completed, shortcomings and deficiencies should be corrected, and all Modification Work Orders (MWO's) should be applied.
- c. Storage site selection. Inside storage is preferred for items selected for administrative storage. If inside storage is not available, trucks, vans, convex containers and other containers may be used.

1.6 NOMENCLATURE CROSS REFERENCE LIST

The following list includes the nomenclature and cross references used in this manual.

Common Name	Official Nomenclature
350 GPM Pump	Pumping Assy, Wheel Mounted, 4-inch, 350 GPM at 275-Foot
350 GPM Pump Connection Kit	Connection Kit, 350 GPM Pump
125 GPM Pump	Pumping Assy, 2-inch, 125 GPM at 50-Foot
125 GPM Pump Connection Kit	Connection Kit, 125 GPM Pump

Common Name	Official Nomenclature
Hypochlorinator	Hypochlorination Unit, Water Purification, Frame Mounted, Automatically Controlled with Bypass, 2 to 400 GPM Flow
Tank Connection Kit	Connection Kit, Dual Tank
20K Water Tank.	Water Tank, Collapsible Fabric, 20,000 Gallon
Tee and Gate Valve Assembly	Valve and Tee Assy, 4-Inch Flanged Connector Assy
Tee Assy	Flanged, Tee Assy, 4-Inch
4-Inch Gate Valve Assy	Valve, Gate, Flanged, 4-Inch
2-Inch Gate Valve Assy	Valve, Gate, Flanged, 2-Inch
Check Valve Assy	Valve, Check, 2-Inch
2-Inch Connectors	Connection, Quick-Disconnect 2-Inch
Nozzle Stand	Stand Assy, Water
Nozzle Connection Kit	Connection Kit, Hose Nozzle
Bag Filler Connection Kit	Connection Kit, Bag Filler
4-Inch by 20-Foot Discharge Hose Assy	Hose Assy, Rubber Smooth Bore, Potable Water Discharge, 4-Inch by 20-Foot Long W/Quick Disconnect Cam-Locking Fittings
4-Inch by 20-Foot Suction Hose Assy	Hose Assy, Rubber, Smooth Bore, Potable Water Suction, 4-Inch by 20-Foot Long W/Quick Disconnect Cam-Locking Fittings
4-Inch by 10-Foot Discharge Hose Assy	Hose Assy, Rubber Smooth Bore, Potable Water Discharge, 4-Inch by 10-Foot Long W/Quick Disconnect Cam-Locking Fittings
4-Inch by 10-Foot Suction Hose Assy	Hose Assy, Rubber Smooth Bore, Potable Water Suction, 4-Inch by 10-Foot Long W/Quick Disconnect Cam-Locking Fittings
4-inch Hose Connection Kit	Connection Kit, 4-Inch Hose
2-Inch by 20-Foot Discharge Hose Assy	Hose Assy, Rubber, Smooth Bore, Potable Water Discharge, 2-Inch by 20-Foot Long W/Quick Disconnect Cam-Locking Fittings
2-Inch by 20-Foot Suction Hose Assy	Hose Assy, Rubber, Smooth Bore, Potable Water Suction, 2-Inch by 20-Foot Long W/Quick Disconnect Cam-Locking Fittings
2-Inch by 10-Foot Discharge Hose Assy	Hose Assy, Rubber, Smooth Bore, Potable Water Discharge, 2-Inch by 10-Foot Long W/Quick Disconnect Cam-Locking Fittings
2-Inch Hose Connection Kit	Connection Kit, 2-Inch Hose
1-1/2-Inch by 25-Foot Discharge Hose Assy	Hose Assy, Rubber, Smooth Bore, Potable Water Discharge, 1-Inch by 25-Foot Long W/Quick Disconnect Cam-Locking Fittings
4-Inch to 2-Inch Reducers	Reducers, Female by Male Quick Disconnect Cam-Locking, 4-Inch to 2-Inch Reducers

Common Name	Official Nomenclature
2-Inch to 4-Inch Reducers	Reducers, Female by Male Quick Disconnect Cam-Locking, 2-Inch to 4-Inch Reducers
2-Inch to 1-1/2-Inch Reducers	Reducers, Female by Male Quick Disconnect Cam-Locking, 2-Inch to 1 -1/2-inch Reducers

1.7 LIST OF ABBREVIATIONS.

K	Kilo (Thousand)
Assy	Assembly
40K WDS	40,000 Gallon Water Distribution System

Section II. EQUIPMENT DESCRIPTION

1.8 EQUIPMENT CHARACTERISTICS, CAPABILITIES AND FEATURES.

a. Characteristics

- (1) Portable
- (2) Self contained
- (3) Adaptable to meet different water supply demands

b. Capabilities and Features

- (1) Easily and quickly set up in the field
- (2) Needs no tools to set up
- (3) Automatically chlorinates water at different flow rates
- (4) Interchangeability of couplings and hoses increases reliability
- (5) No outside power requirements needed

1.9 LOCATION AND DESCRIPTION OF SYSTEM COMPONENTS.

125 GPM PUMP CONNECTION KIT (1). Contains couplings, hoses, components necessary to connect 125 GPM pump to the water system.

125 GPM PUMP (2). Pumps water under pressure through the water system. Refer to TM 5-4320-304-14 or TM 10-4320-309-14 for additional pump information.

DUAL TANK CONNECTION KIT (3). Contains hoses, valves, and couplings needed to connect two 20,000 gallon water tanks to the system.

WATER TANKS (4). Store 20,000 gallons of potable water. Assume pillow shape when filled. Handles on sides of tanks aid movement when tank is empty. When not in use, the tanks may be folded or rolled and stored in the tank chest. The system is supplied with three 20K tanks. Two tanks are used during normal setup, the third tank is a spare. Refer to TM 5-5430-226-12 for additional information on the water tank.

350 GPM PUMP CONNECTION KIT (5). Contains components necessary to connect the 350 GPM pump to the water system.

350 GPM PUMP (6). Supplies water under pressure to the water system. Refer to TM 5-4320-226-14 for a description of the 350 GPM pump.

WATER METER (7). Measures amount of water flow.



HYPOCHLORINATION UNIT (8). Injects hypochlorite solution into water in direct proportion to water flow rate. Refer to TM 5-4610-233-13&P for a description of the hypochlorinator.

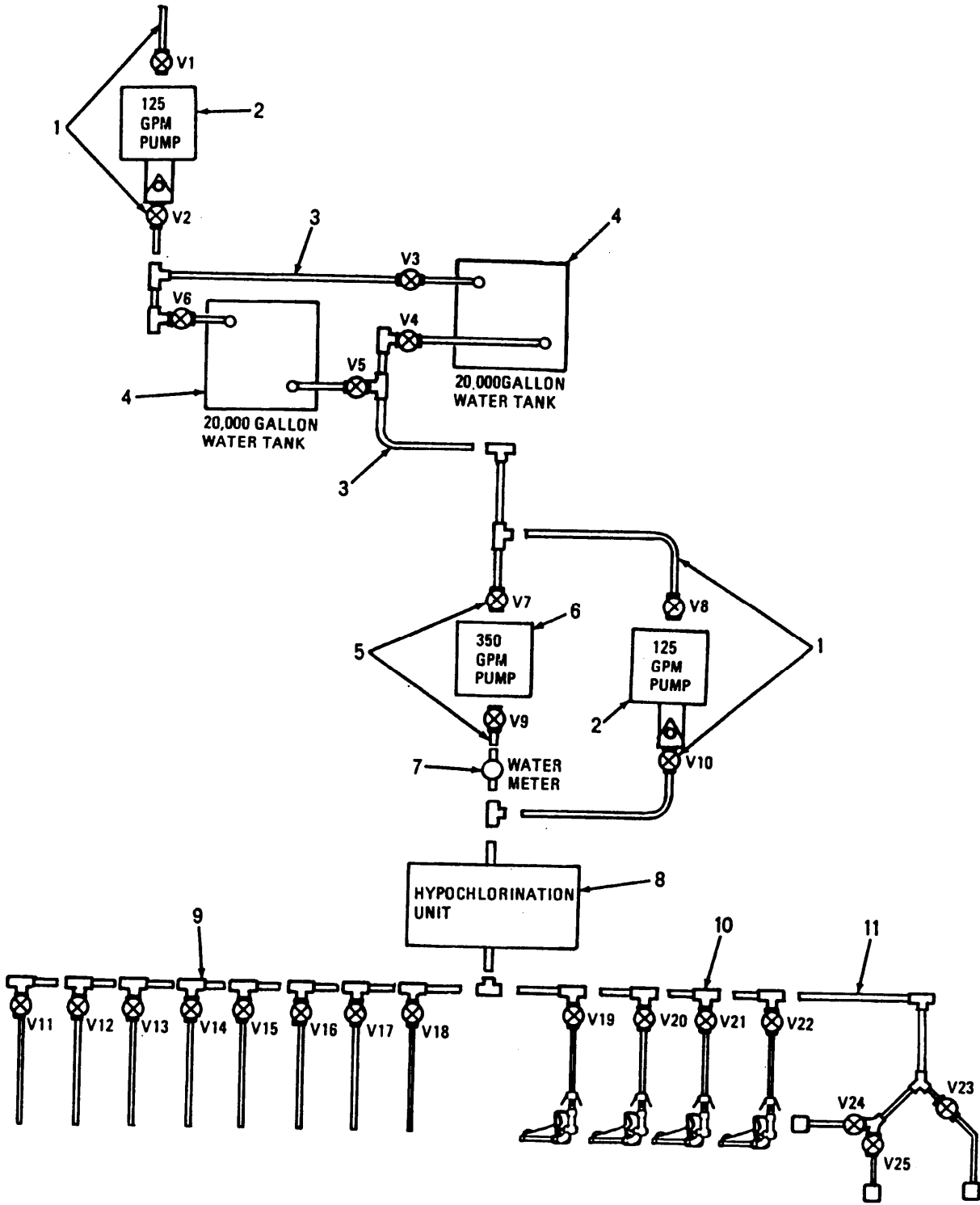

40K Water Distribution System

1.9 LOCATION AND DESCRIPTION OF SYSTEM COMPONENTS-Cont.

2-INCH HOSE CONNECTION KIT (9). Contains 2-inch hose connections for filling tankers, trailers and other large capacity containers.

HOSE NOZZLE CONNECTION KIT (10). Contains hand-operated nozzles used to dispense water to field users. Each nozzle connection kit has a quick disconnect connector and a swivel for ease of operation.

BAG FILLER CONNECTION KIT (I 1). Contains hand operated nozzle dispensers used to fill water bags.

ACCESSORY KIT (Not shown). Contains additional hoses, valves, couplings and fittings. Components are used to adapt the water system to varying site and operational requirements.

WATER TANK CHEST (Not shown). Reusable container stores water tanks and accessories when not in use.

1.10 EQUIPMENT DATA (Refer to Table 1-1).

Table 1-1. Equipment Data

Hypochlorination Unit (Refer to TM 5-4610-233-13&P).	
350 GPM Pumping Assembly (Refer to TM 5-4320-226-14).	
125 GPM Pumping Assembly (Refer to TM 5-4320-304-14 or TM 10-4320-309-14).	
20,000 Gallon Fabric Collapsible Water Tank (Refer to TM 5-5430-226-12).	
Water Tank Chest.	
Weight (grins)	2,200 lb
Length	13 ft. 8 in.
Width	3 ft. 8 in.
Height	3 ft
Capacity	1000 lb

Section III. TECHNICAL PRINCIPLES OF OPERATION

1.11 GENERAL.

The water distribution system described in this manual is configured for maximum storage and distribution capacity. Your operating requirements will determine how many of the system components must be connected and in what configuration. Additional components are available in the accessory kit to adapt the system to varying site and operational needs. Another water system maybe connected to this equipment to increase storage and/or distribution capacity.

1.12 TECHNICAL PRINCIPLES OF OPERATION.

Water used in the 40K system is supplied by the Tactical Water Distribution pipeline or other source. Water drawn into the 40K system by the 125 or 350 GPM pump is supplied to the water storage tanks through 4-inch collapsible discharge hoses. Control of water flow between the water supply pump and the water tanks is performed by opening or dosing gate valves on the filler side of the dual tank connection kit. The tanks may be filled at the same time or filled separately, depending on operating requirements. By filling one 20,000 gallon water tank at a time, the system can discharge water almost immediately after set up.

Potable water is stored in the 20,000 gallon collapsible fabric tanks until needed. When water is required downstream, gate valves on the discharge side of the dual tank connection kit are opened. Water then flows from the tank(s) to the suction side of the 350 and 125 GPM discharge pumps. For detailed water tank principles of operation, refer to TM 5-5430-226-12.

Water flow from the storage tanks to the loading stations is provided by the 350 and 125 GPM discharge pumps. The pumps are connected in parallel and supply water on demand at a rate determined by the nozzles, discharge hoses, or bag filler connections. If discharge demand is less than the capacity of one pump, the other pump can be shut down and the related pump valves closed. For detailed water pump principles of operation, refer to TM 5-4320-304-14 or TM 10-4320-309-14 (125 GPM pump) and TM 5-4320-226-14 (350 GPM pump).

Discharge water is treated by the hypochlorination unit before arriving at the loading stations. The hypochlorination unit mixes a hypochlorite solution with the water in correct proportion to water flow. For detailed hypochlorination unit principles of operation, refer to TM 10-4610-233-13&P,

Loading stations dispense water to field users. Hose and nozzle dispensers allow filling of water tank trailers (water buffaloes,) water bags, buckets, and related storage containers.

1.13 SAFETY CARE AND HANDLING.

Observe all Warning, Cautions and Notes in this manual. This equipment can be dangerous or maybe damaged if these instructions are not followed.

CHAPTER 2 OPERATING INSTRUCTIONS

Section I. DESCRIPTION AND USE OF OPERATOR'S CONTROLS AND INDICATORS

	Page
Introduction.....	2-1
Gate Valves.....	2-2
Distribution Nozzles.....	2-3
WaterMeter.....	2-4

2.1 INTRODUCTION.

This section provides information needed by the operator to locate, identify, and use the controls and indicators required to operate the 40K Water Distribution System. The components and controls identified in this section are applicable to the entire system. Refer to the applicable technical manuals for controls and indicators on the following equipment:

Equipment	Technical Manual
Hypochlorination Unit	TM 5-4610-233-13&P
350 GPM Pump	TM 5-4320-226-14
125 GPM Pump	TM 5-4320-304-14 or TM 10-4320-309-14
20,000 Gallon Collapsible Fabric Tank	TM 5-5430-226-12



2.2 GATE VALVES.

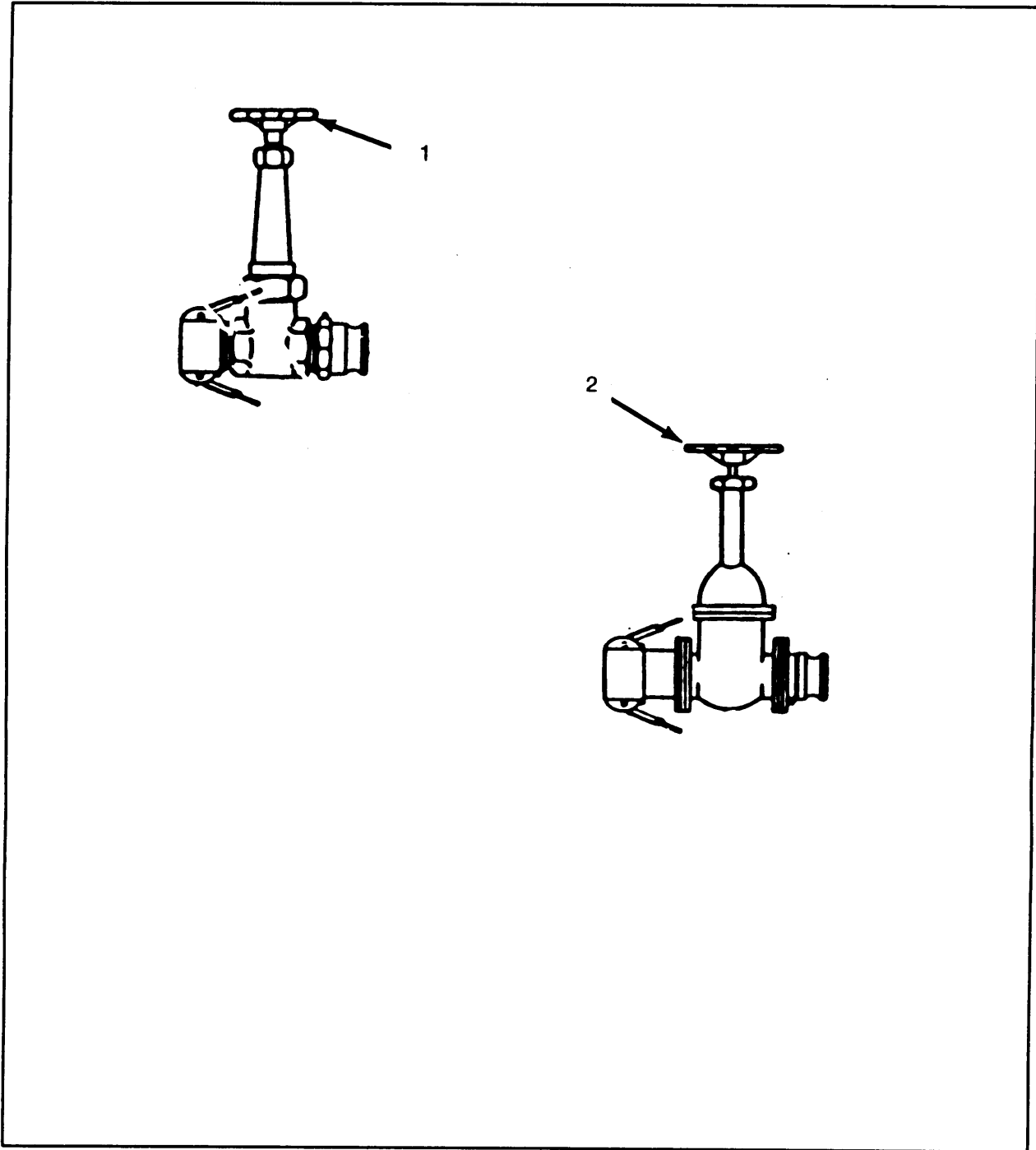

KEY	CONTROL OR INDICATOR	FUNCTION
1	Handwheel - 2-inch hand operated gate valve.	Opens and closes valve.
2	Handwheel - 4-inch hand operated gate valve.	Opens and closes valve.

2.3 DISTRIBUTION NOZZLES.

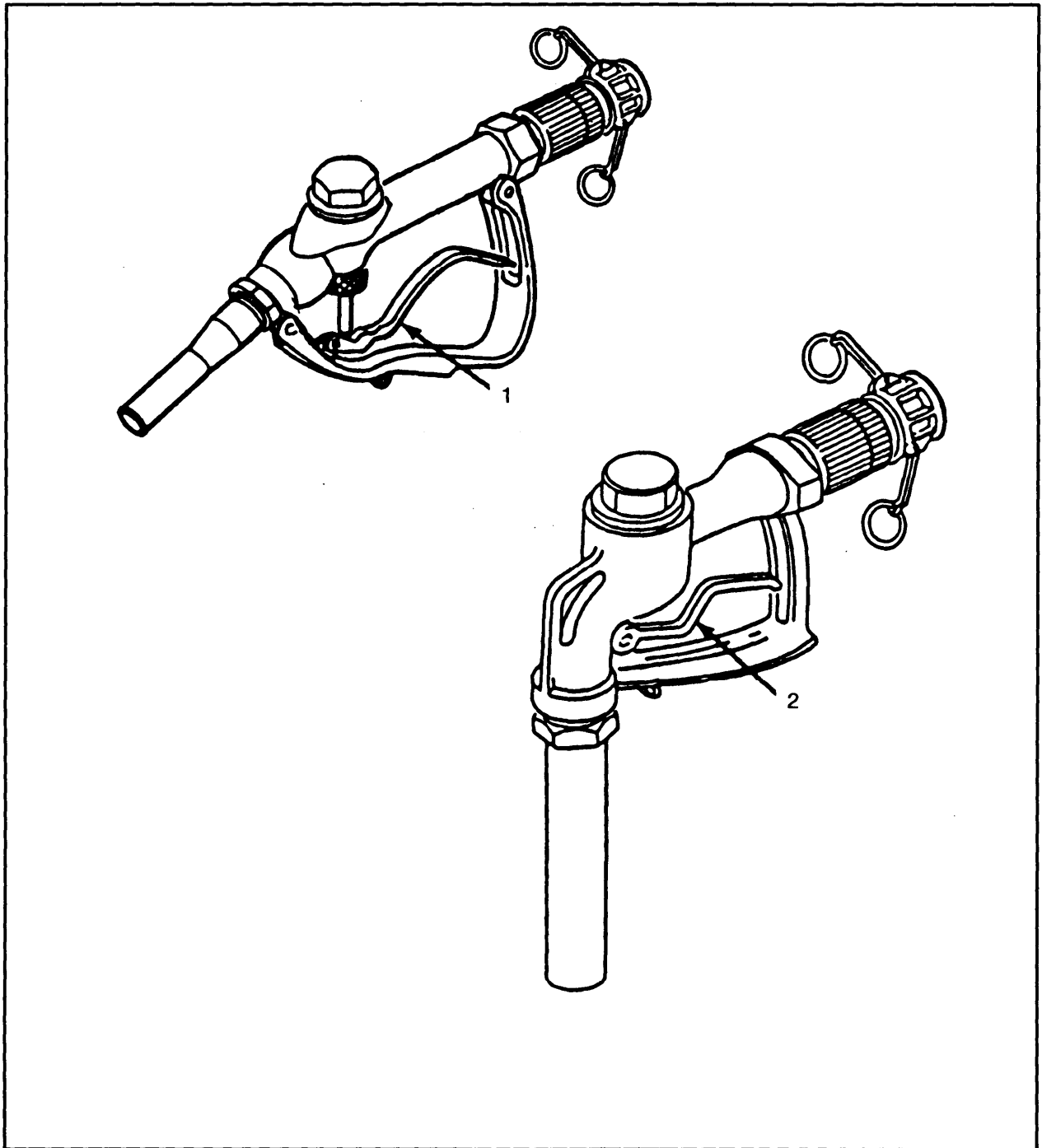

KEY	CONTROL OR INDICATOR	FUNCTION
1	Distribution Nozzle Handle (1-inch)	Starts and stops water flow from nozzle.
2	Distribution Nozzle Handle (1-1/2-inch)	Starts and stops water flow from nozzle.

2.4 WATER METER.

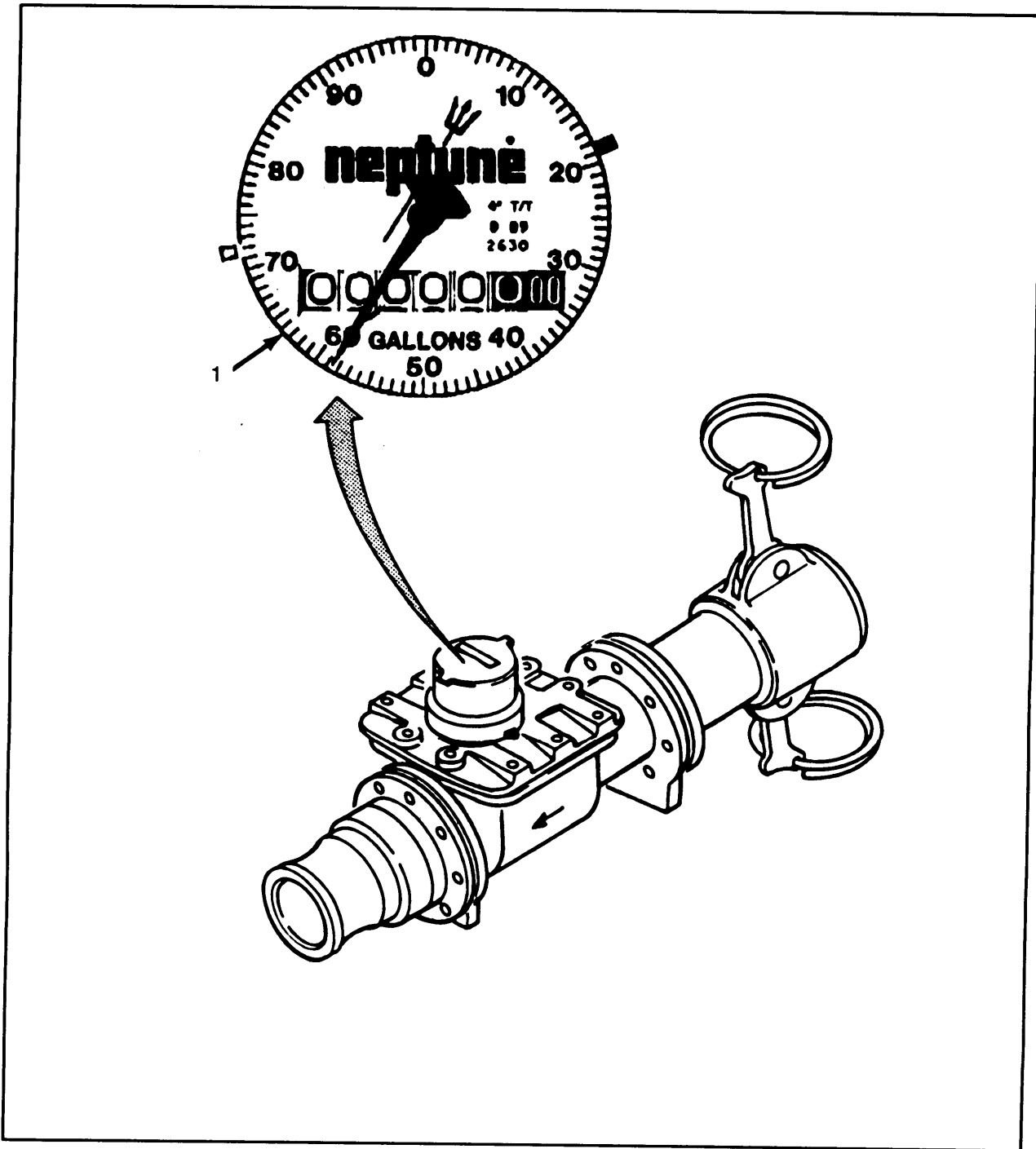

KEY	CONTROL OR INDICATOR	FUNCTION
1	Water meter indicator	Shows total amount of water supplied to loading stations (measured in gallons).

Section II
OPERATOR PREVENTIVE MAINTENANCE CHECKS AND SERVICES (PMCS)

Introduction	Page 2-5
Operator Preventive Maintenance Checks And Sewices	2-6

2.5 INTRODUCTION.

a. General. Your Preventive Maintenance Checks and Services table lists the inspections and care of your equipment required to keep it in good operating condition. The interval column of your PMCS table tells you when to do a certain check or service. The procedures column of the table tells you how to do the required task. Carefully follow these instructions. If your equipment does not perform as required, refer to Chapter 3, Operator Troubleshooting Procedures.

- (1) Before You Operate. Always keep in mind the CAUTIONS and WARNINGS. Perform your Before PMCS.
- (2) While You Operate. Always keep in mind the CAUTIONS and WARNINGS. Perform your During PMCS.
- (3) After You Operate. Be sure to perform your After PMCS.
- (4) If Your Equipment Fails to Operate. If your equipment does not perform as required, refer to Chapter 3, Operator Troubleshooting Procedures for possible problems. Report any malfunctions or failures on DA Form 2404, or refer to DA PAM 738-750.

b. PMCS PROCEDURES.

- (1) Purposese of PMCS. Your Preventive Maintenance Checks and Services list the inspections and servicing requirements necessary to keep the equipment in good operating condition.
- (2) Item Number Column. Checks and services are numbered in chronological order regardless of interval. This column is used as a source of item number for the "TM Number" column on DA Form 2404, Equipment Inspection and Maintenance Worksheet, in recording results of PMCS.
- (3) Interval Columns. The interval columns tell you when to do a certain check or service: before, during, or after operation.
- (4) Items To Be Inspected/Procedure Column. This column lists the common name of the item to be inspected such as "Drive Belts" and tells you how to do the required checks or services. Carefully follow these instructions. If you do not have the tools, or if the procedures tell you to, have unit maintenance do the work.
- (5) Not Mission Capable If Column. This column tells you when and why your equipment cannot be used.

NOTE

The terms ready/available and mission capable refer to the same status: equipment is on hand and is able to perform its combat missions. (See DA PAM 738-750).

c. Leakage Definitions.

- | | |
|----------|---|
| Class I | Seepage of fluid (as indicated by wetness or discoloration) not great enough to form drops. |
| Class II | Leakage of fluid great enough to form drops, but not enough to cause drops to drip from item being checked/inspected. |

Class III Leakage of fluid great enough to form drops that fall from the item being checked/inspected.

2.6 OPERATOR PREVENTIVE MAINTENANCE CHECKS AND SERVICES.



Equipment operation is allowable with minor leakages (CLASS I or II). Of course, you must consider the fluid capacity in the item/system being checked/inspected. When in doubt, notify your supervisor.

NOTE

If the equipment must be kept in continuous operation, check and service only those items that can be checked and serviced without disturbing operation. Make the complete checks and services when the equipment can be shut down.

Table 2-1. Operator Preventive Maintenance Checks and Services.

Item No.	Interval	Location	Procedure	Not Mission Capable If:
		Item To Check/ Service		
1	Before	40K Gallon Water Storage and Distribution System (End Item)	Inspect entire system for physical damage and missing components.	Major components are damaged or missing.
2	Before	Bag Filler Connection Kit	Inspect for loose coupling connections. Reconnect and lock loose couplings.	Couplings loose or disconnected.
3	Before	Discharge Hose	a. Inspect hoses for cuts, tears, and deep abrasions. b. Inspect couplings for cracks and bent or broken locking arms. Inspect for cut, torn or missing coupling gaskets. Check for missing dust caps and plugs.	Hoses cut or torn. Coupling damaged. Gaskets damaged or missing.
4	Before	Gate Valves	a. Inspect for loose, broken, or missing hand wheel. b. Inspect valve couplings for cracks and bent or broken locking arms. Inspect for cut, torn or missing coupling gaskets. Check for missing dust caps and plugs. c. Rotate hand wheel. Valve stem should turn freely. d. Check for loose or missing bolts and nuts. e. Inspect valve stem, bonnet, and flange gaskets for leaks.	Hand wheel broken or missing. Coupling damaged. Gaskets damaged or missing. Valve stem sticks or binds. Hardware missing. Valve leaks (Class III).

Table 2-1. Operator Preventive Maintenance Checks and Services. (cont.)

Item No.	Interval	Location		Procedure	Not Mission Capable If:
		Item To Check/ Service			
5	Before	Tee Assemblies		a. Inspect tee fittings for cracks, breaks, and severe corrosion. b. Inspect couplings for cracks and bent or broken locking arms. Inspect for cut, torn or missing coupling gaskets. Check for missing dust caps and plugs.	Tee cracked or severely corroded. Coupling or gasket damaged. Gasket missing.
6	Before	Distribution Nozzles		a. Inspect for bent or crushed nozzle tube. b. Inspect for bent broken or stuck nozzle control handle. c. Inspect for binding stuck or broken nozzle swivel.	Nozzle crushed. Handle broken or stuck.
7	Before	Water Pressure Regulator		Inspect for loose or missing nuts, bolts and washers.	Hardware missing.
8	Before	Nozzle Stand		a. Inspect for bent legs and missing hardware. b. Inspect for broken or missing support chains.	Legs bent or hardware missing. Support chain missing.
9	Before	Hose Nozzle Connection Kit		Inspect for loose coupling connections. Reconnect and lock loose couplings.	
10	Before	Distribution Nozzles		a. Inspect for bent or crushed nozzle tube. b. Inspect for bent broken or stuck nozzle control handle. c. Inspect for binding stuck or broken nozzle swivel.	Nozzle crushed. Handle broken or stuck.
11	Before	Discharge Hoses		a. Inspect hoses for cuts, tears, and deep abrasions. b. Inspect couplings for cracks and bent or broken locking arms. Inspect for cut, torn or missing coupling gaskets. Check for missing dust caps and plugs.	Hoses cut or torn. Coupling damaged. Gaskets damaged or missing.

Table 2-1. Operator Preventive Maintenance Checks and Services. (cont.)

Item No.	Interval	Location	Procedure	Not Mission Capable If:
		Item To Check/ Service		
12	Before	Gate Valves	<p>a. Inspect for loose or missing hand wheel.</p> <p>b. Inspect valve couplings for cracks and bent or broken locking arms. Inspect for cut, torn or missing coupling gaskets. Check for missing dust caps and plugs.</p> <p>c. Rotate hand wheel. Valve stem should turn freely.</p> <p>d. Check for loose or missing bolts and nuts.</p>	<p>Hand wheel missing.</p> <p>Coupling damaged.</p> <p>Gaskets damaged or missing.</p> <p>Valve stem sticks or binds.</p> <p>Hardware missing.</p>
13	Before	Tee Assemblies	<p>a. Inspect tee fittings for cracks, breaks, and severe corrosion.</p> <p>b. Inspect couplings for cracks and bent or broken locking arms. inspect for cut, torn or missing coupling gaskets. Check for missing dust caps and plugs.</p>	<p>Tee cracked severely corroded.</p> <p>Coupling or gasket damaged. Gasket missing.</p>
14	Before	Nozzle Stand	<p>a. Inspect for bent legs and missing attaching hardware.</p> <p>b. Inspect for broken or missing support chains.</p>	<p>Legs bent or hardware missing.</p> <p>Support chain missing.</p>
15	Before	Hose Connection Kit, 2-inch	<p>Inspect for loose coupling connections. Reconnect and lock loose couplings.</p>	
16	Before	Discharge Hoses	<p>a. Inspect hoses for cuts, tears, and deep abrasions.</p> <p>b. Inspect couplings for cracks and bent or broken locking arms. Inspect for cut, torn or missing coupling gaskets. Check for missing dust caps and plugs.</p>	<p>Hoses cut or torn.</p> <p>Coupling damaged.</p> <p>Gaskets damaged or missing.</p>
17	Before	Gate Valves	<p>a. Inspect for loose or missing hand wheel.</p> <p>b. Inspect valve couplings for cracks and bent or broken locking arms. Inspect for cut, torn or missing coupling gaskets. Check for missing dust caps and plugs.</p> <p>c. Rotate hand wheel. Valve stem should turn freely.</p> <p>d. Check for loose or missing bolts and nuts.</p>	<p>Hand wheel missing.</p> <p>Coupling damaged.</p> <p>Gaskets damaged or missing.</p> <p>Valve stem sticks or binds.</p> <p>Hardware missing.</p>

Table 2-1. Operator Preventive Maintenance Checks and Services. (cont.)

Item No.	Interval	Location		Procedure	Not Mission Capable If:
		Item To Check/ Service			
18	Before	Tee Assemblies		a. Inspect tee fittings for cracks, breaks, and severe corrosion. b. Inspect couplings for cracks and bent or broken locking arms. inspect for cut, torn or missing coupling gaskets. Check for missing dust caps and plugs.	Tee cracked or severely corroded. Coupling or gasket damaged. Gasket missing.
19	Before	Nozzle Stand		a. Inspect for bent legs and missing attaching hardware. b. Inspect for broken or missing support chains.	Legs bent or hardware missing. Support chain missing,
20	Before	Hypochlorination Unit		Refer to TM 5-4610-233-13&P for operator PMCS.	
21	Before	350 GPM Pump Connection Kit		Inspect for loose coupling connections. Reconnect and lock loose couplings.	
22	Before	Tee Assemblies		a. Inspect tee fittings for cracks, breaks and severe corrosion. b. Inspect couplings for cracks and bent or broken locking arms. inspect for cut, torn or missing coupling gaskets. Check for missing dust caps and plugs.	Tee cracked or severely corroded. Coupling or gasket damaged. Gasket missing.
23	Before	Suction Hoses		a. Inspect hoses for cuts, tears, and deep abrasions. b. Inspect couplings for cracks and bent or broken locking arms. inspect for cut, torn or missing coupling gaskets. Check for missing dust caps and plugs.	Hoses cut or torn. Couplings cracked, bent or broken.
24	Before	Gate Valves		a. Inspect for loose or missing hand wheel. b. Inspect valve couplings for cracks and bent or broken locking arms. Inspect for cut, torn or missing coupling gaskets. Check for missing dust caps and plugs. c. Rotate hand wheel. Valve stem should turn freely. d. Check for loose or missing bolts and nuts,	Hand wheel missing. Coupling damaged. Gaskets damaged or missing. Valve stem sticks or binds. Hardware missing.

Table 2-1. Operator Preventive Maintenance Checks and Services. (cont.)

Item No.	Interval	Location	Procedure	Not Mission Capable If:
		Item To Check/ Service		
25	Before	Discharge Hoses	<p>a. Inspect hoses for cuts, tears, and deep abrasions.</p> <p>b. Inspect couplings for cracks and bent or broken locking arms. Inspect for cut, torn or missing coupling gaskets. Check for missing dust caps and plugs.</p>	<p>Hoses cut or torn.</p> <p>Coupling damaged. Gaskets damaged or missing.</p>
26	Before	Water Meter Assembly	<p>a. Inspect meter indicator for damage, moisture on inside of glass cover, and loose or missing screws.</p> <p>b. Check for loose or missing bolts and nuts.</p> <p>c. Inspect couplings for cracks and bent or broken locking arms. Inspect for cut, torn or missing coupling gaskets. Check for missing dust caps and plugs.</p>	<p>Indicator cracked.</p> <p>Hardware missing.</p> <p>Coupling or gasket damaged. Gasket missing.</p>
27	Before	350 GPM Pumping Assembly	Refer to TM 5-4320-226-14 for operator PMCS.	
28	Before	125 GPM Connection Kit	Inspect for loose coupling connections. Reconnect and lock loose couplings.	
29	Before	Discharge Hoses	<p>a. Inspect hoses for cuts, tears, and deep abrasions.</p> <p>b. Inspect couplings for cracks and bent or broken locking arms. Inspect for cut, torn or missing coupling gaskets. Check for missing dust caps and plugs.</p>	<p>Hoses cut or torn.</p> <p>Coupling damaged. Gaskets damaged or missing.</p>
30	Before	Gate Valves	<p>a. Inspect for loose or missing hand wheel.</p> <p>b. Inspect valve couplings for cracks and bent or broken locking arms. Inspect for cut, torn or missing coupling gaskets. Check for missing dust caps and plugs.</p> <p>c. Rotate hand wheel. Valve stem should turn freely.</p> <p>d. Check for loose or missing bolts and nuts.</p>	<p>Hand wheel missing.</p> <p>Coupling damaged. Gaskets damaged or missing.</p> <p>Valve stem sticks or binds.</p> <p>Hardware missing.</p>
31	Before	Check Valve	Inspect valve body for cracks and leaks.	Body cracked or leaking (Class III).

Table 2-1. Operator Preventive Maintenance Checks and Services. (cont.)

Item No.	Interval	Location	Procedure	Not Mission Capable If:
		Item To Check/ Service		
32	Before	Suction Hoses	<p>a. Inspect hoses for cuts, tears, and deep abrasions.</p> <p>b. Inspect couplings for cracks and bent or broken locking arms. inspect for cut, torn or missing coupling gaskets. Check for missing dust caps and plugs.</p>	<p>Hoses cut or torn.</p> <p>Coupling or gasket damaged. Gasket missing.</p>
33	Before	Pumping Assembly 125 GPM	Refer to TM 5-4320-304-14 or TM 10-4320-309-14 for operator PMCS.	
34	Before	Dual Tanks Connection Kit	Inspect for loose coupling connections. Reconnect and lock loose couplings.	
35	Before	Discharge Hoses	<p>a. Inspect hoses for cuts, tears, and deep abrasions.</p> <p>b. Inspect couplings for cracks and bent or broken locking arms. Inspect for cut, torn or missing coupling gaskets. Check for missing dust caps and plugs.</p>	<p>Hoses cut or torn.</p> <p>Coupling damaged. Gaskets damaged or missing.</p>
36	Before	Gate Valve	<p>a. Inspect for loose or missing hand wheel.</p> <p>b. Inspect valve couplings for cracks and bent or broken locking arms. Inspect for cut, torn or missing coupling gaskets. Check for missing dust caps and plugs.</p> <p>c. Rotate hand wheel. Valve stem should turn freely.</p> <p>d. Check for loose or missing bolts and nuts.</p>	<p>Hand wheel missing.</p> <p>Coupling damaged. Gaskets damaged or missing.</p> <p>Valve stem sticks or binds.</p> <p>Hardware missing.</p>
37	Before	Suction Hoses	<p>a. Inspect hoses for cuts, tears, and deep abrasions.</p> <p>b. Inspect couplings for cracks and bent or broken locking arms. inspect for cut, torn or missing coupling gaskets. Check for missing dust caps and plugs.</p>	<p>Hoses cut or torn.</p> <p>Couplings cracked, bent or broken.</p>
38	Before	20,000 Gallon Collapsible Fabric Tank	Refer to TM 5-5430-226-12 for operator PMCS.	
39	Before	Accessory Kit	Inspect for damaged, missing or corroded components.	

Table 2-1. Operator Preventive Maintenance Checks and Services. (cont.)

Item No.	Interval	Location		Procedure	Not Mission Capable If:
		Item To Check/ Service			
40	Before	Water Tank Chest		Inspect for cracks, broken side panels, missing rivets, and broken latches.	
41	During	Bag Filler Connection Kit		Inspect for loose coupling connections. Reconnect and lock loose couplings.	Couplings loose or disconnected.
42	During	Discharge Hose		a. Inspect hoses for cuts, tears, and deep abrasions. b. inspect hoses for leaks.	Hoses cut or tom. Hose leaks (Class III).
43	During	Tee Assemblies		Inspect for leaks at couplings and flange gaskets.	Tee assembly leaks (Class III).
44	During	Distribution Nozzles		a. Inspect for bent or crushed nozzle tube. b. Inspect for bent, broken or stuck nozzle control handle. c. Inspect for binding, stuck or broken nozzle swivel. d. Check for leaks at swivel and nozzle body.	Nozzle crushed. Handle broken or stuck. Nozzle leaks (Class III).
45	During	Water Pressure Regulator		a. Inspect for loose or missing nuts, bolts and washers. b. Inspect regulator body for leaks.	Hardware missing. Regulator leaks (Class III).
Hose Nozzle Connection Kit					
46	During	Distribution Nozzles		a. Inspect for bent or crushed nozzle tube. b. Inspect for bent broken or stuck nozzle control handle. c. Inspect for binding, stuck or broken nozzle swivel. d. Check for leaks at swivel and nozzle body.	Nozzle crushed. Handle broken or stuck. Nozzle leaks (Class III).
47	During	Discharge Hoses		a. Inspect hoses for cuts, tears, and deep abrasions. b. Inspect hoses for leaks.	Hoses cut or tom. Hose leaks (Class III).
48	During	Gate Valves		Inspect valve stem, bonnet, and flange gaskets for leaks.	Valve leaks (Class III).
49	During	Tee Assemblies		Inspect for leaks at couplings and flange gaskets.	Tee assembly leaks (Class III).

Table 2-1. Operator Preventive Maintenance Checks and Services. (cont.)

Item No.	Interval	Location		Procedure	Not Mission Capable If:
		Item To Check/Service			
Hose Connection Kit, 2-inch					
50	During	Discharge Hoses		a. Inspect hoses for cuts, tears, and deep abrasions. b. Inspect hoses for leaks.	Hoses cut or tom. Hose leaks (Class III).
51	During	Tee Assemblies		Inspect for leaks at couplings and flange gaskets.	Tee assembly leaks (Class III).
350 GPM Pump Connection Kit					
52	During	Tee Assemblies		Inspect for leaks at couplings and flange gaskets.	Tee assembly leaks (Class III).
53	During	Suction Hoses		Inspect hose for signs of collapse. Hose should keep its shape when pumps are operating.	Hose collapses under suction.
54	During	Gate Valves		Inspect valve stem, bonnet, and flange gaskets for leaks.	Valve leak (Class III).
55	During	Discharge Hoses		a. Inspect hoses for cuts, tears, and deep abrasions. b. Inspect hoses for leaks.	Hoses cut or tom. Hose leaks (Class III).
125 GPM Pump Connection Kit					
56	During	Discharge Hoses		a. Inspect hoses for cuts, tears, and deep abrasions. b. Inspect hoses for leaks.	Hoses cut or tom. Hose leaks (Class III).
57	During	Gate Valves		Inspect valve stem, bonnet, and flange gaskets for leaks.	Valve leak (Class III).
58	During	Check Valve		Inspect valve body for cracks and leaks.	Body cracked or leaking (Class III).
59	During	Suction Hose		Inspect hose for signs of collapse. Hose should keep its shape when pumps are operating.	Hose collapses under suction.
Dual Tanks Connection Kit					
60	During	Discharge Hoses		a. Inspect hoses for cuts, tears, and deep abrasions. b. Inspect hoses for leaks.	Hoses cut or tom. Hose leaks (Class III).
61	During	Gate Valves		Inspect valve stem, bonnet, and flange gaskets for leaks.	Valve leak (Class III).
62	During	Suction Hoses		Inspect hose for signs of collapse. Hose should keep its shape when pumps are operating.	Hose collapses under suction.

Table 2-1. Operator Preventive Maintenance Checks and Services. (cont.)

Item No.	Interval	Location	Procedure	Not Mission Capable If:
		Item To Check/ Service		
63	During	Water Tank Chest	Inspect for cracks, broken side panels, missing rivets, and broken latches.	
64	After	40K Gallon Water Storage and Distribution System (End Item)	Inspect entire system for physical damage and missing components.	Major components are damaged or missing.
Bag Filler Connection Kit				
65	After	Gate Valves	<p>a. Inspect for loose, broken, or missing hand wheel.</p> <p>b. Inspect valve couplings for cracks and bent or broken locking arms. Inspect for cut, torn or missing coupling gaskets, Check for missing dust caps and plugs.</p> <p>c. Rotate hand wheel. Valve stem should turn freely.</p> <p>d. Check for loose or missing bolts and nuts.</p> <p>e. Inspect valve stem, bonnet, and flange gaskets for leaks.</p>	<p>Hand wheel broken or missing.</p> <p>Coupling damaged. Gaskets damaged or missing.</p> <p>Valve stem sticks or binds.</p> <p>Hardware missing.</p> <p>Valve leaks (Class III).</p>
66	After	Tee Assemblies	Inspect couplings for cracks and bent or broken locking arms. inspect for cut, tom or missing coupling gaskets. Check for missing dust caps and plugs.	Coupling or gasket damaged. Gasket missing.
67	After	Distribution Nozzles	<p>a. Inspect for bent or crushed nozzle tube.</p> <p>b. Inspect for bent, broken or stuck nozzle control handle.</p>	<p>Nozzle crushed.</p> <p>Handle broken or stuck.</p>
68	After	Water Pressure Regulator	Inspect for loose or missing nuts, bolts and washers.	Hardware missing.
Hose Nozzle Connection Kit				
69	After	Distribution Nozzles	<p>a. Inspect for bent or crushed nozzle tube.</p> <p>b. Inspect for bent, broken or stuck nozzle control handle.</p>	<p>Nozzle crushed.</p> <p>Handle broken or stuck,</p>

Table 2-1. Operator Preventive Maintenance Checks and Services. (cont.)

Item No.	Interval	Location	Procedure	Not Mission Capable If:
		Item To Check/ Service		
70	After	Gate Valve	<p>a. Inspect for loose or missing hand wheel.</p> <p>b. Inspect valve couplings for cracks and bent or broken locking arms. Inspect for cut, torn or missing coupling gaskets. Check for missing dust caps and plugs.</p> <p>c. Rotate hand wheel. Valve stem should turn freely.</p> <p>d. Check for loose or missing bolts and nuts.</p>	<p>Hand wheel missing.</p> <p>Coupling damaged. Gaskets damaged or missing.</p> <p>Valve stem sticks or binds.</p> <p>Hardware missing.</p>
71	After	Tee Assemblies	<p>Inspect valve couplings for cracks and bent or broken locking arms. Inspect for cut, torn or missing coupling gaskets. Check for missing dust caps and plugs.</p>	<p>Coupling or gasket damaged. Gasket missing.</p>
Hose Connection Kit, 2-inch				
72	After	Gate Valves	<p>a. Inspect for loose or missing hand wheel.</p> <p>b. Inspect valve couplings for cracks and bent or broken locking arms. Inspect for cut, torn or missing coupling gaskets. Check for missing dust caps and plugs.</p> <p>c. Rotate hand wheel. Valve stem should turn freely.</p> <p>d. Check for loose or missing bolts and nuts.</p>	<p>Hand wheel missing.</p> <p>Coupling damaged. Gaskets damaged or missing.</p> <p>Valve stem sticks or binds.</p> <p>Hardware missing.</p>
73	After	Tee Assemblies	<p>Inspect valve couplings for cracks and bent or broken locking arms. Inspect for cut, torn or missing coupling gaskets. Check for missing dust caps and plugs.</p>	<p>Coupling or gasket damaged. Gasket missing.</p>
350 GPM Pump Connection Kit				
74	After	Tee Assemblies	<p>Inspect couplings for cracks and bent or broken locking arms. inspect for cut, torn or missing coupling gaskets. Check for missing dust caps and plugs.</p>	<p>Coupling or gasket damaged. Gasket missing.</p>

Table 2-1. Operator Preventive Maintenance Checks and Services. (cont.)

Item No.	Interval	Location		Procedure	Not Mission Capable If:
		Item To Check/ Service			
75	After	Gate Valves		a. Inspect for loose or missing hand wheel. b. Inspect valve couplings for cracks and bent or broken locking arms. Inspect for cut, torn or missing coupling gaskets. Check for missing dust caps and plugs. c. Rotate hand wheel. Valve stem should turn freely. d. Check for loose or missing bolts and nuts.	Hand wheel missing. Coupling damaged. Gaskets damaged or missing. Valve stem sticks or binds. Hardware missing.
76	After	Water Meter Assembly		a. Check for loose or missing bolts and nuts. b. Inspect couplings for cracks and bent or broken locking arms. Inspect for cut, torn or missing coupling gaskets. Check for missing dust caps and plugs.	Hardware missing. Coupling or gasket damaged. Gasket missing.
77	After	Gate Vales		a. Inspect for loose or missing hand wheel. b. inspect valve couplings for cracks and bent or broken locking arms. Inspect for cut, torn or missing coupling gaskets. Check for missing dust caps and plugs. c. Rotate hand wheel. Valve stem should turn freely. d. Check for loose or missing bolts and nuts.	Hand wheel missing. Coupling damaged. Gaskets damaged or missing. Valve stem sticks or binds. Hardware missing.
78	After	Check Valves		Inspect valve body for cracks and leaks.	Body cracked or leaking (Class III).
Dual Tanks Connection Kit					
79	After	Gates Valves		a. Inspect for loose or missing hand wheel. b. Inspect valve couplings for cracks and bent or broken locking arms. Inspect for cut, torn or missing coupling gaskets. Check for missing dust caps and plugs. c. Rotate hand wheel. Valve stem should turn freely. d. Check for loose or missing bolts and nuts.	Hand wheel missing. Coupling damaged. Gaskets damaged or missing. Valve stem sticks or binds. Hardware missing.

Table 2-1. Operator Preventive Maintenance Checks and Services. (cont.)

Item No.	Interval	Location	Procedure	Not Mission Capable If:
		Item To Check/Service		
80	After	Accessory Kit	Inspect for damaged, missing or corroded components.	
81	After	Water Tank Chest	Inspect for cracks, broken side panels, missing rivets, and broken latches.	

Section III. OPERATION UNDER USUAL CONDITIONS

Assembly And Preparation For Use. 2-19
 Decals And Instruction Plates. 2-37
 General. 2-17
 Initial Adjustments. 2-17
 Operation. 2-35
 Preparation For Movement. 2-37
 Quick Disconnect Couplings. 2-17
 Unpacking. 2-17

2.7 GENERAL

These procedures describe the operation, assembly, and preparation of the water distribution system in the fill and discharge modes of operation. The fill mode of operation fills the water storage tanks and the discharge mode draws water from the water storage tanks. The fill and discharge modes of operation can be performed at the same time. Before attempting to operate your water distribution system, become thoroughly familiar with the operation of all components.

2.8 UNPACKING.

Three 20K Gallon Collapsible Fabric Tanks are packaged in two reusable water tank chests. One chest contains two tanks, the other contains one tank and the accessories for all three tanks. The water tank chests are unpacked by unit maintenance.

2.9 INITIAL ADJUSTMENT.

Inspect the equipment for damage incurred during unpacking and shipment. Report any problems to unit maintenance. Refer to 20,000 Gallon Collapsible Fabric Tank, 350 GPM Pump Assembly, 125 GPM Pump Assembly, and Hypochlorination Unit technical manuals for initial adjustment procedures for this equipment.

2.10 QUICK DISCONNECT COUPLINGS.

NOTE

All suction and discharge hoses, gate valves, and fitting used in the 40K Water Distribution System utilize quick disconnect cam-lock couplings to permit rapid connection and disconnection of system components. The following instructions apply to all operator installation tasks.

2.10 QUICK DISCONNECT COUPLINGS -continued

a. Connection.



Use care when connecting coupling to avoid getting dirt, sand and debris on coupling mating surfaces or in hoses. To prevent leaks and ensure tight connections, make sure gaskets are installed in all male quick disconnect couplings.

- (1) Lift locking arms (2) up and away from female coupling (3).
- (2) Position male coupling (4) in female coupling (3).
- (3) While holding couplings together, pull locking arms (2) back and down against female coupling (3).
- (4) Test coupling connection by pulling on connected hoses(1 and 5). Hoses should remain securely connected.

b. Disconnection.



Do not disconnect hose couplings while water system is pressurized. Hose ends may whip, causing injury to personnel and damage to equipment.

- (1) Pull locking arms (2) up and away from female couplings (3).
- (2) Disconnect female couplings (3) from male couplings (4).

2.11 ASSEMBLY AND PREPARATION FOR USE.

a. Site Selection and Preparation.

- (1) Select a level, debris free area. Site must be large enough to contain all system components.



To avoid injury, two personnel are required to position 125 and 350 GPM pumps.

- (2) Place one 125 GPM pump (discharge pump) at water source. Position pump so that female quick disconnect coupling points toward water source.
- (3) Place 350 GPM and 125 GPM discharge pumps in position with female couplings facing toward water tank installation site and male couplings toward site chosen for water distribution.
- (4) Prepare 125 GPM pumps for use in accordance with TM 5-4320-304-14 or TM 10-4320-309-14.
- (5) Prepare 350 GPM pump for use in accordance with TM 5-4320-226-14.

Warning

To avoid injury, four personnel are required to position water tanks.

NOTE

Position water tanks about 12 feet apart

- (6) Place 20K water tanks in position at installation site. Assemble and prepare water tanks for use in accordance with TM5-5430-226-12.

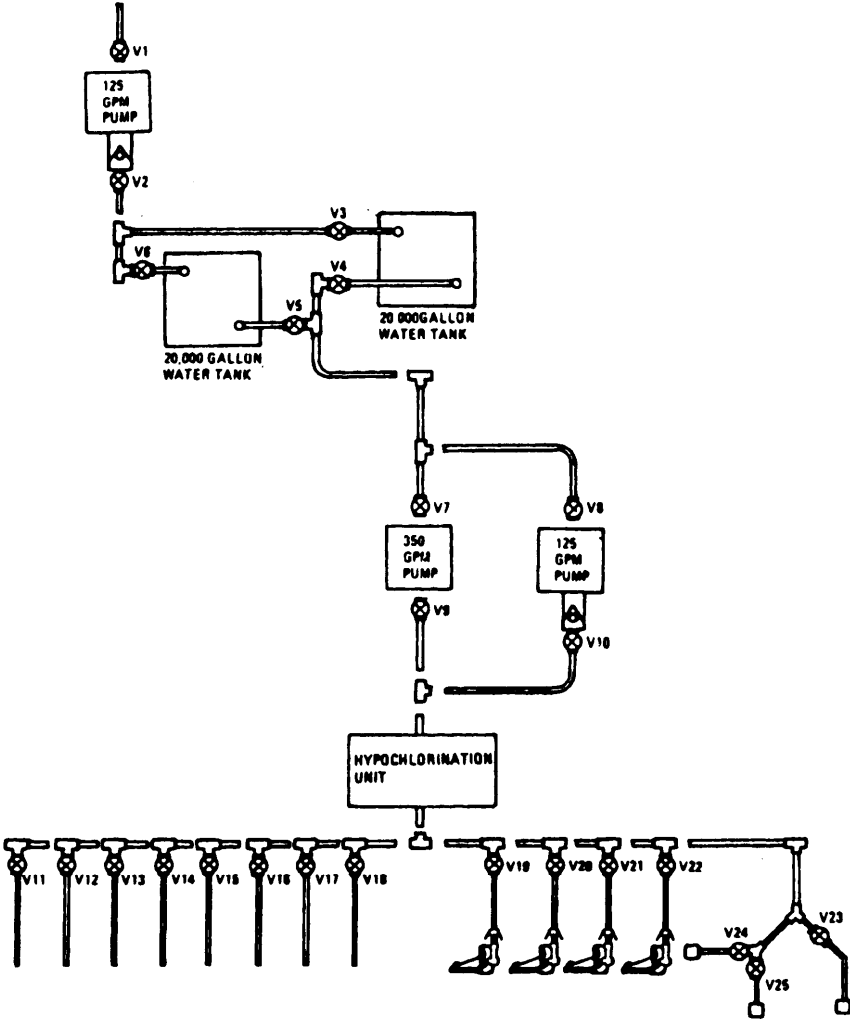

40K Water Distribution System Assembly

2.11 ASSEMBLY AND PREPARATION FOR USE - continued

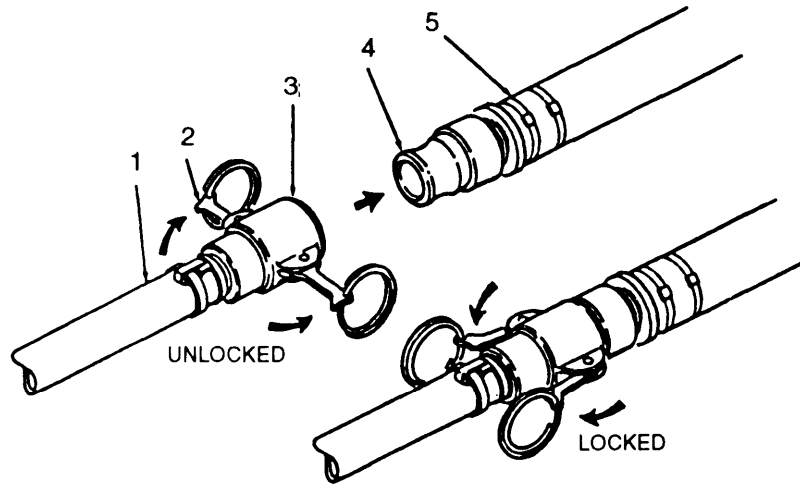

Quick Disconnect Couplings

- b. 125 GPM Pump Connect Kit Assembly (water source). Two 125 GPM pump connection kits are supplied with this system. Assemble the 125 GPM pump connection kit located at the water source (pipeline) as follows:

Warning

To prevent contamination of drinking water, make sure water tank elbows are capped and plugged when system hoses are not connected to tank.

CAUTION

CAUTION Before connecting hoses, make sure suction (rigid) hoses only are installed between pump and water source. If this is not done, damage to hoses and pump can occur,

NOTE

- Install all gate valves with hand wheel in upright position and valve fully closed.
- Suction hoses are noncollapsible and discharge hoses are collapsible.

- (1) Connect suction hose (4) to suction side (female coupling) of 125 GPM pump assembly.
- (2) Connect gate valve assembly (3) to suction hose (4).
- (3) Connect suction hose (2) to gate valve assembly (3).
- (4) Connect reducer (1) to suction hose (2).
- (5) Connect reducer (1) to water source.
- (6) Connect discharge hose (5) to discharge side (male coupling) of 125 GPM pump assembly.
- (7) Connect check valve (6) to discharge hose (5).
- (8) Connect gate valve assembly (7) to check valve (6).
- (9) Connect discharge hose (8) to gate valve assembly (7).
- (10) Connect reducer (9) to discharge hose (8).

2.11 ASSEMBLY AND PREPARATION FOR USE - continued

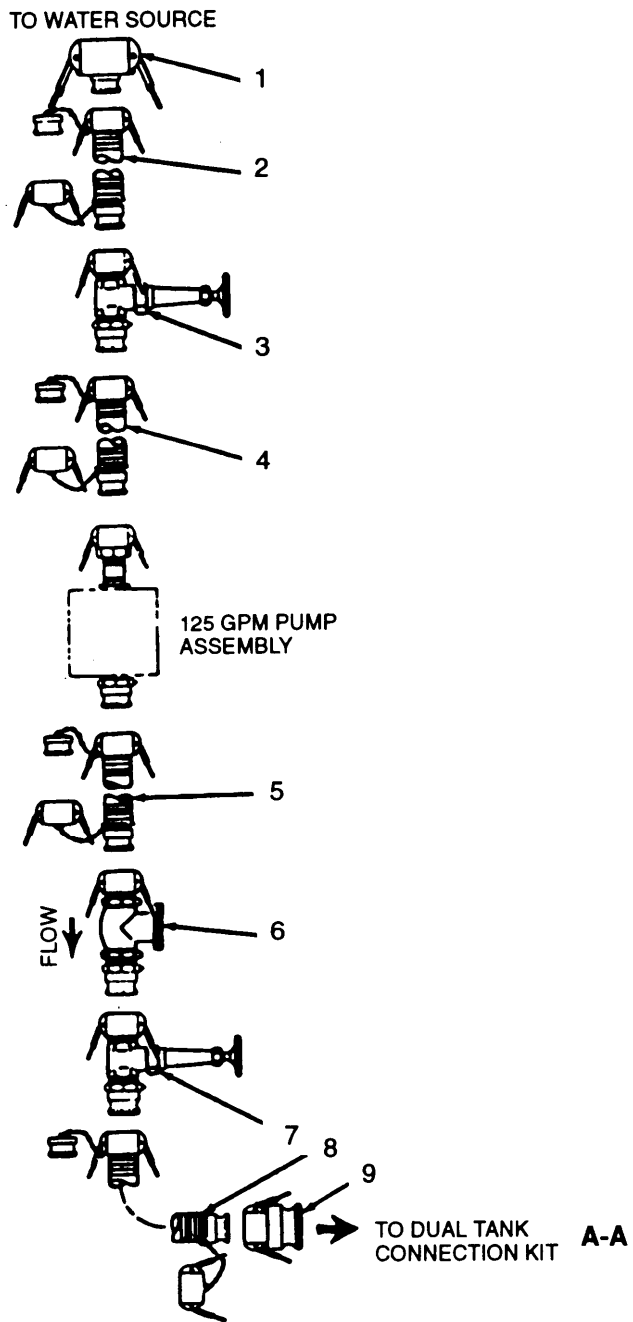

125 GPM Pump Connection Kit (source)

c. Dual Tank Connection Kit Assembly. Assemble dual tank connection kit as follows:

Warning

To prevent contamination of drinking water, make sure water tank elbows are capped and plugged when system hoses are not connected to tank.

NOTE

- Install all gate valves with hand wheel in upright position and valve fully closed.
 - To aid assembly, work from the water tanks back to the 125 GPM pump connection kit. Adjust spacing between water tanks and reposition connection kit components as needed to prevent kinks in hoses.
 - Suction hoses are noncollapsible and discharge hoses are collapsible.
- (1) Connect suction hose (20 ft) (14) to discharge elbow (male) on water tank (13).
 - (2) Connect suction hose (20 ft) (19) to discharge elbow (male) on water tank (18).
 - (3) Connect tee and gate valve assembly (15) to suction hose (14).
 - (4) Connect tee and gate valve assembly (17) to suction hose (19).
 - (5) Connect suction hose (20 ft) (16) between tee and gate valve assemblies (15 and 17).
 - (6) Connect suction hose (10 ft) (26) to tee and gate valve assembly (15).
 - (7) Connect discharge hose (20 ft) (24) to filler elbow (female) on water tank (18).
 - (8) Connect tee and gate valve assembly (20) to discharge hose (24).
 - (9) Connect discharge hoses (20 ft and 10 ft) (21 and 22) to tee and gate valve assembly (20).
 - (10) Get tee (23) from accessory connection kit. Connect tee to discharge hose (22).
 - (11) Connect discharge hose (20 ft) (12) to filler elbow (female) on water tank (13).
 - (12) Connect tee and gate valve assembly (11) to discharge hose (12).
 - (13) Connect discharge hose (10 ft) (10) to tee and gate valve assembly (11).
 - (14) Connect discharge hose (10 ft) (25) to discharge hose (10) and tee (23).
 - (15) Connect tee (23) (from accessory kit) to reducer (9) on 125 GPM pump connection kit. (See connection points A-A.)

2.11 DUAL TANK CONNECTION KIT ASSEMBLY - -continued

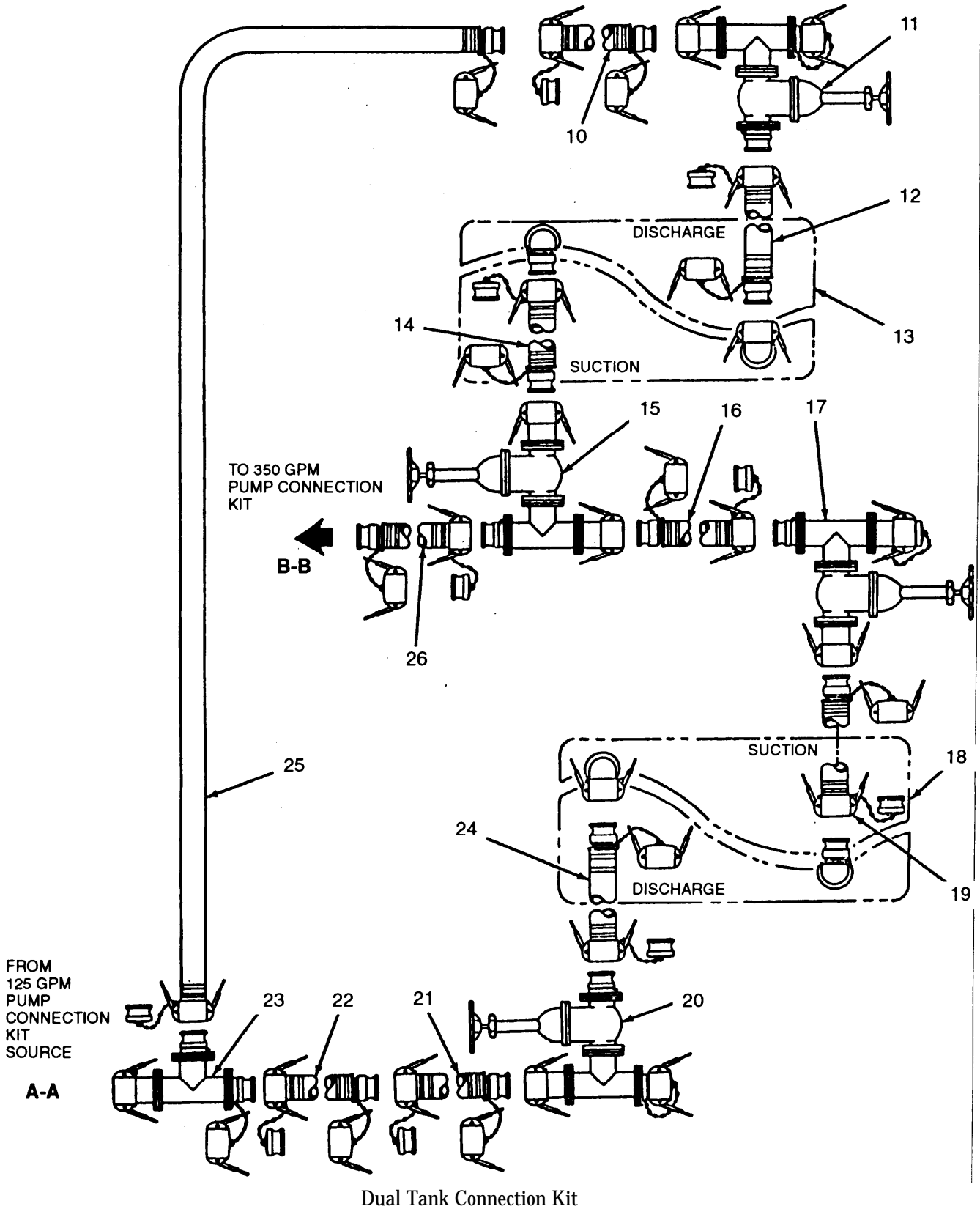

d. 350 GPM Pump Assembly Connection Kit Assembly.

Warning

To prevent contamination of drinking water, make sure protective caps and plugs are installed when components are not in use.

NOTE

- Install all gate valves with hand wheel in upright position and valve fully closed.
- Suction hoses are noncollapsible and discharge hoses are collapsible.

- (1) Connect suction hose (20 ft) (40) to suction side of 350 GPM pump assembly.
- (2) Connect gate valve assembly (4) to suction hose (40).
- (3) Connect tee (42) to gate valve assembly (41).
- (4) Connect suction hose (20 ft) (43) to tee (42).
- (5) Connect tee (44) to suction hose (43).
- (6) Connect discharge hose (20 ft) (38) to discharge side of 350 GPM pump assembly.
- (7) Connect gate valve assembly (37) to discharge hose (20 ft) (38).
- (8) Connect discharge hose (39) to gate valve assembly (37).
- (9) Connect tee (35) to discharge hose (39).
- (10) Position hypochlorination unit near tee (35). Connect tee (35) to hypochlorination unit.
- (11) Connect tee (34) to hypochlorination unit.

e. 125 GPM Pump Assembly Connection Kit Assembly

- (1) Connect suction hose (20 ft) (29) to suction side of 125 GPM pump assembly.
- (2) Connect gate valve assembly (28) to suction hose (29).
- (3) Connect suction hose (20 ft) (27) to gate valve assembly (28).
- (4) Connect reducer (45) to suction hose (27).
- (5) Connect reducer (45) to tee (42) on 350 GPM pump connection kit.
- (6) Connect discharge hose (20 ft) (30) to discharge side of 125 GPM pump assembly.
- (7) Connect check valve (31) to discharge hose (30).
- (8) Connect gate valve (32) to check valve (31).
- (9) Connect discharge hose (20 ft) (33) to gate valve (32).
- (10) Connect reducer (36) to discharge hose (33).
- (11) Connect reducer (36) to tee (35) on 350 GPM pump connection kit.
- (12) Connect discharge hose (26) from dual tank connection kit to tee (44). (See connection point B-B.)

2.11 ASSEMBLY PREPARATION FOR USE - continued

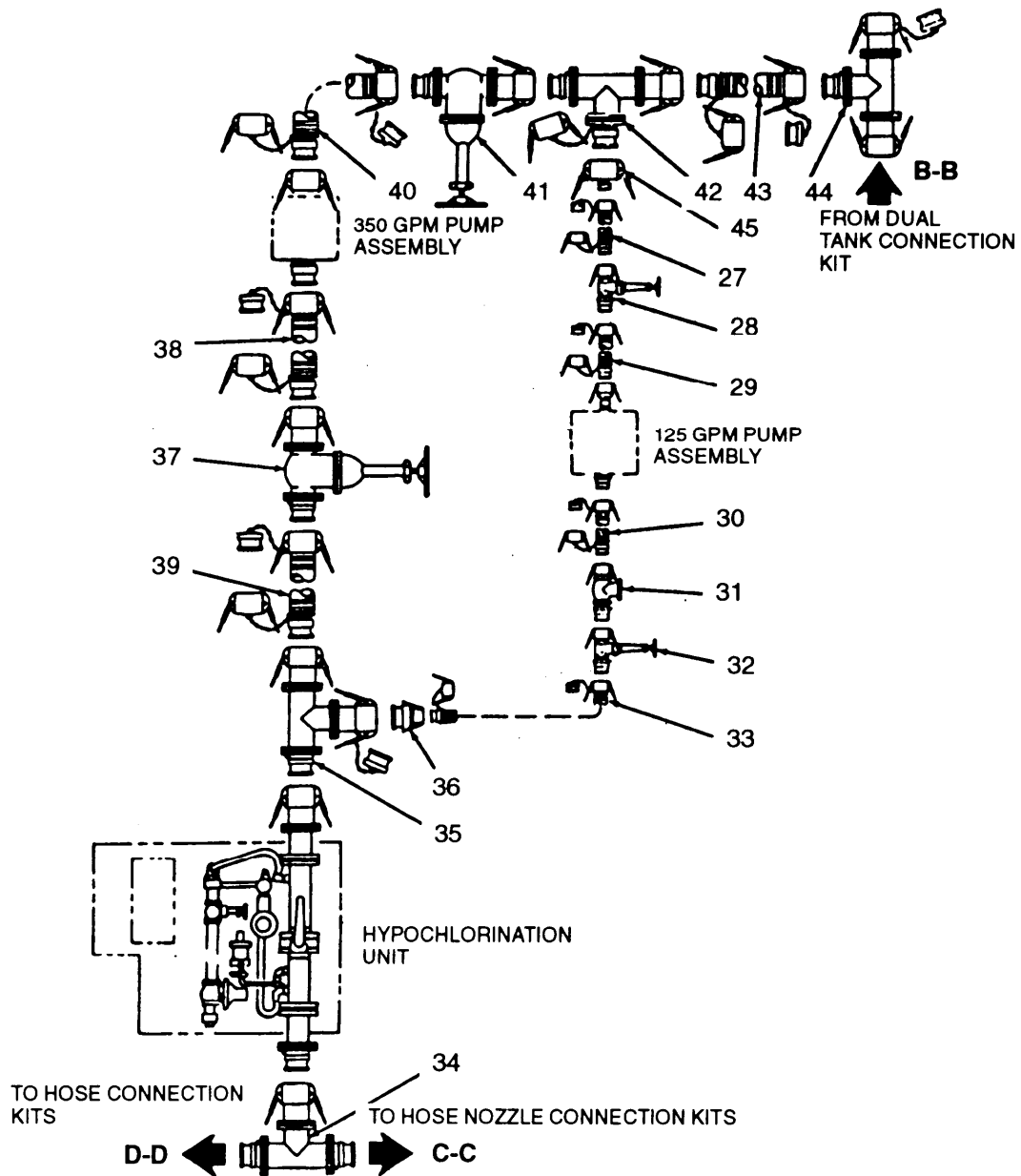

350 and 125 GPM Pump Connection Kits

f. Hose Connection Kit Assembly.

Warning

To prevent contamination of drinking water, make sure protective caps and plugs are installed in component when not in use.

NOTE

- Install all gate valves with hand wheel in upright position and valve fully closed.
 - Eight hose connection kits are used in the 40K Water Distribution System. After each kit is assembled, they are all connected to form one distribution point.
- (1) Connect tee (34) from 350 GPM connection kit to discharge hose (20 ft) (47). (See connection point D-D.)
 - (2) Connect discharge hose (20 ft) (48) to discharge hose (47).
 - (3) Connect tee (46) to discharge hose (48).
 - (4) Connect reducer (49) to tee (46).
 - (5) Connect gate valve (50) to reducer (49).
 - (6) Connect discharge hose (20 ft) (51) to gate valve (50).
 - (7) Repeat steps (2) through (6) to assemble seven remaining connection kits.
 - (8) Connect seven remaining kits.
 - (9) Unfold nozzle stand assembly (52) and attach discharge hose (51) to bracket on stand.

2.11 ASSEMBLY AND PREPARATION FOR USE - cent.

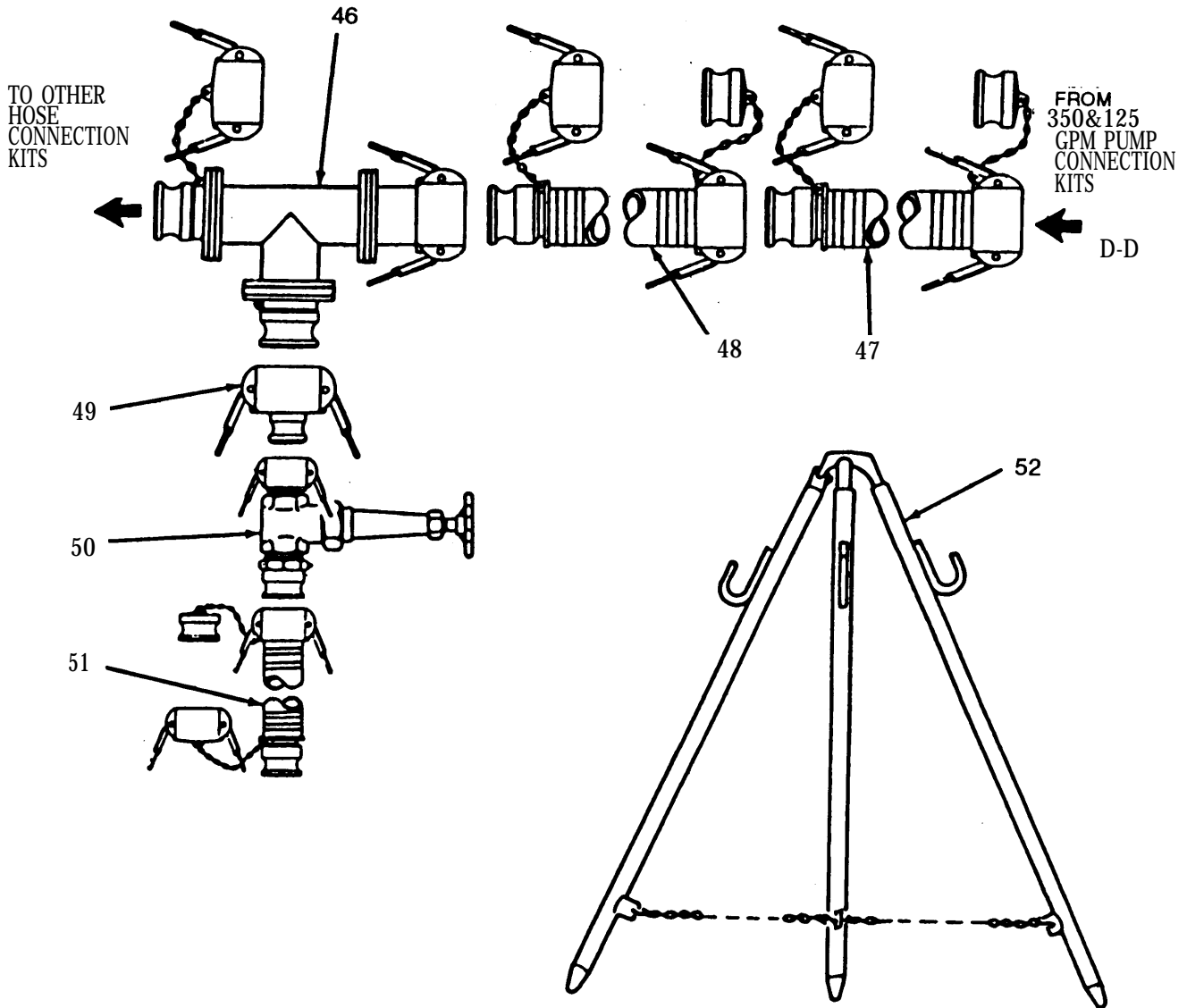

Hose Connection Kit

9. Hose Nozzle Connection Kit Assembly

Warning

To prevent contamination of drinking water, make sure protective caps and plugs are installed in components when not in use.

NOTE

- Install all gate valves with hand wheel in upright position and valve fully closed.
 - Four nozzle connection kits are used in the 40K Water Distribution System. After each kit is assembled, they are all connected to form one distribution point.
- (1) Connect discharge hose (53) to tee (35) (See connection point C-C).
 - (2) Connect discharge hose (20 ft) (54) to discharge hose (53).
 - (3) Connect tee (61) to discharge hose (54).
 - (4) Connect reducer (55) to tee (61).
 - (5) Connect gate valve (56) to reducer (55).
 - (6) Connect discharge hose (20 ft) (57) to gate valve (56).
 - (7) Connect reducer (58) to discharge hose (57).
 - (8) Connect discharge hose (25 ft) (59) to reducer (58).
 - (9) Connect distribution nozzle (60) to discharge hose (59).
 - (10) Unfold nozzle stand (62) and attach distribution nozzle (60) to bracket on stand.
 - (11) Assemble three remaining hose nozzle connection kits as described in steps (2) through (10).
 - (12) Connect all hose nozzle connection kits together.

2.11 ASSEMBLY AND PREPARATION FOR USE - continued

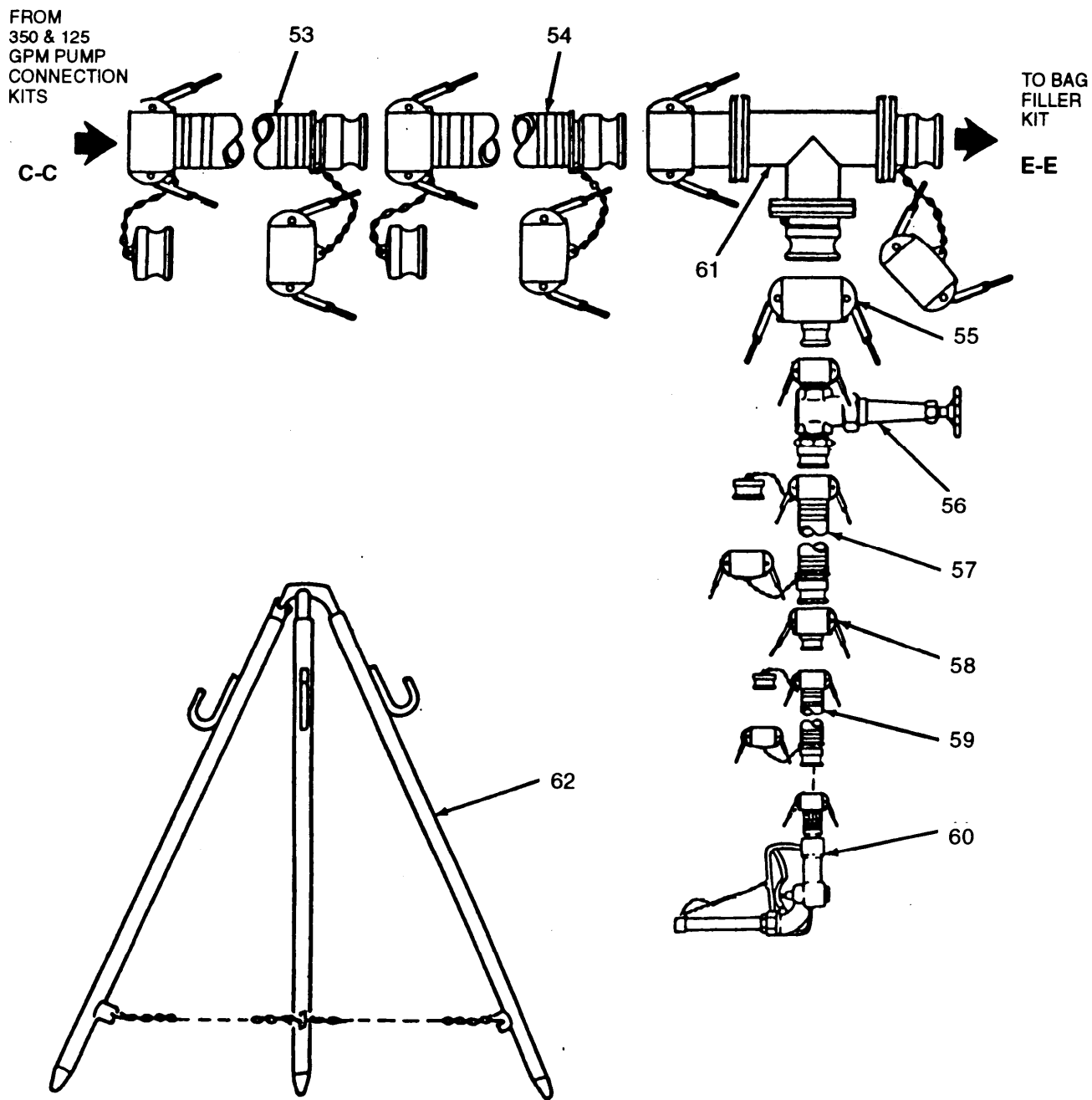

Hose Nozzle Connection Kit

h. Bag Filler Connection Kit Assembly.**Warning**

To prevent contamination of drinking water, make sure protective caps and plugs are installed in component when not in use.

NOTE

- Install all gate valves with hand wheel in upright position and valve fully closed.
 - Bag filler kit is connected to the last hose nozzle connection kit.
- (1) Connect discharge hose (20 ft) (63) to tee (61) (point E-E) on hose nozzle connection kit.
 - (2) Connect discharge hose (20 ft) (64) to discharge hose (63).
 - (3) Connect tee (65) to discharge hose (64).
 - (4) Connect reducer (77) to tee (65).
 - (5) Connect discharge hose (20 ft) (66) to reducer (77).
 - (6) Connect wye (67) to discharge hose (66).
 - (7) Connect discharge hose (20 ft) (68) to wye (67).
 - (8) Connect gate valve (69) to discharge hose (68).
 - (9) Connect discharge hose (25 ft) (70) to gate valve (69).
 - (10) Connect discharge hose (20 ft) (76) to wye (67).
 - (11) connect wye (75) to discharge hose (76).
 - (12) Connect gate valve (72) to wye (75) and discharge hose (25 ft) (71) to gate valve (72).
 - (13) Connect gate valve (74) to wye (75) and discharge hose (25 ft) (73) to gate valve (74).

2.11 ASSEMBLY AND PREPARATION FOR USE - continued

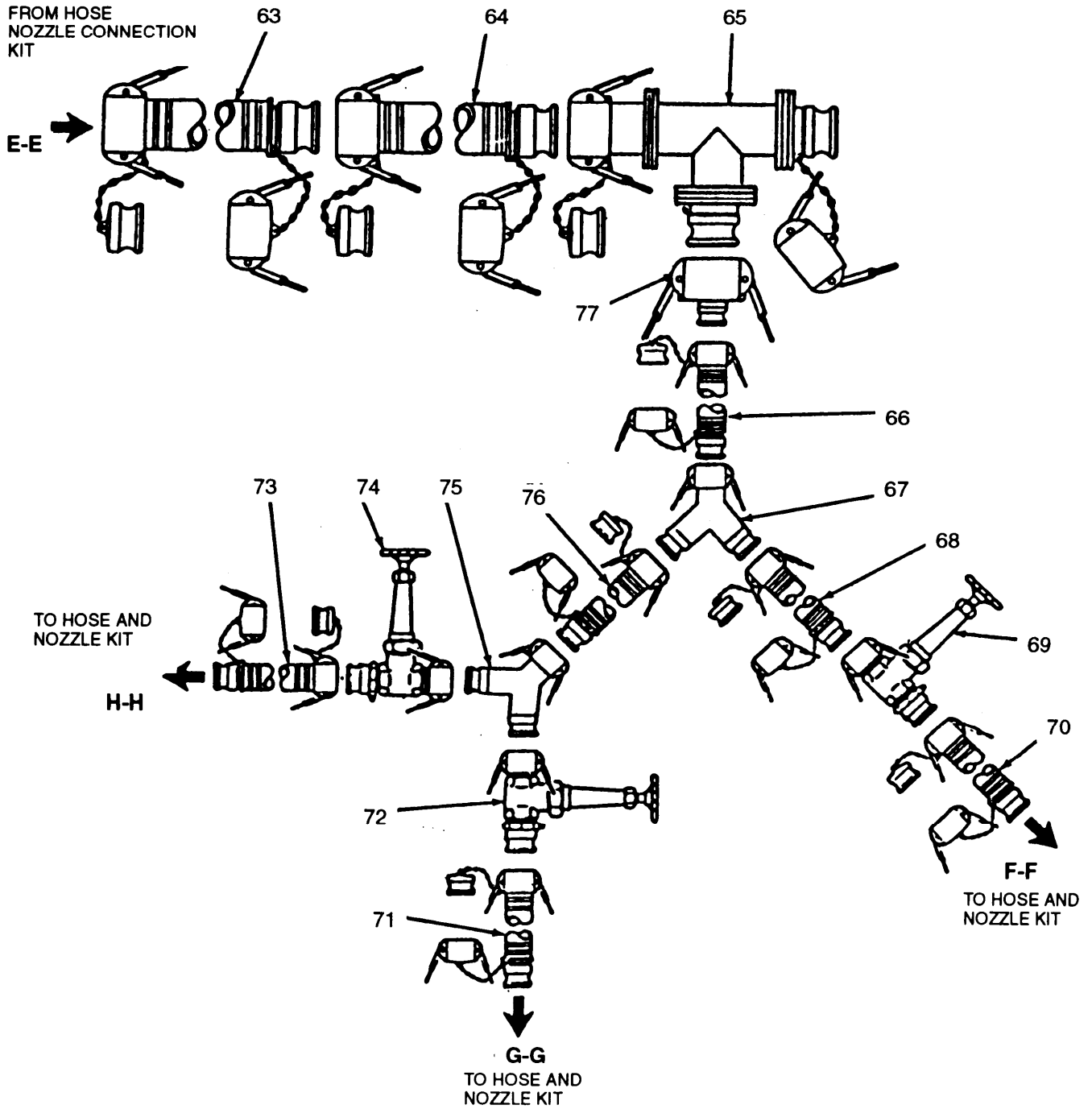

Bag Filler Connection Kit

i. Hose and Nozzle Kit Assembly



Warning

To prevent contamination of drinking water, make sure protective caps and plugs are installed in component when not in use.

NOTE

- Install all gate valves with hand wheel in upright position and valve fully closed.
 - Three hose and nozzle kits are supplied with the 40K Water Distribution System. These kits are connected to the bag filler connection kit at connection points F-F, G-G, and H-H.
- (1) Connect reducer (78) to hoses at connection point F-F, G-G, or H-H on bag filler connection kit.
 - (2) Connect discharge hose (79) to reducer (78).
 - (3) Connect discharge hose (80) to discharge hose (79).
 - (4) Position pressure regulator (81) near discharge hose (80). Connect discharge hose to regulator.
 - (5) Connect discharge (82) to pressure regulator (81).
 - (6) Connect discharge hose (83) to discharge hose (82).
 - (7) Connect distribution nozzle (84) to discharge hose (83).
 - (8) Unfold nozzle stand (85) and place distribution nozzle (84) on hanger.
 - (9) Repeat steps 1 through 8 for two remaining hose and nozzle kits.
 - (10) Connect reducer (77) of one hose and nozzle kit to discharge hose (70) (point F-F) on bag filler kit.
 - (11) Connect reducer (77) of second hose and nozzle kit to discharge hose (71) (point G-G) on bag filler kit.
 - (12) Connect reducer (77) of third hose and nozzle kit to discharge hose (73) (point H-H) on bag filler kit.

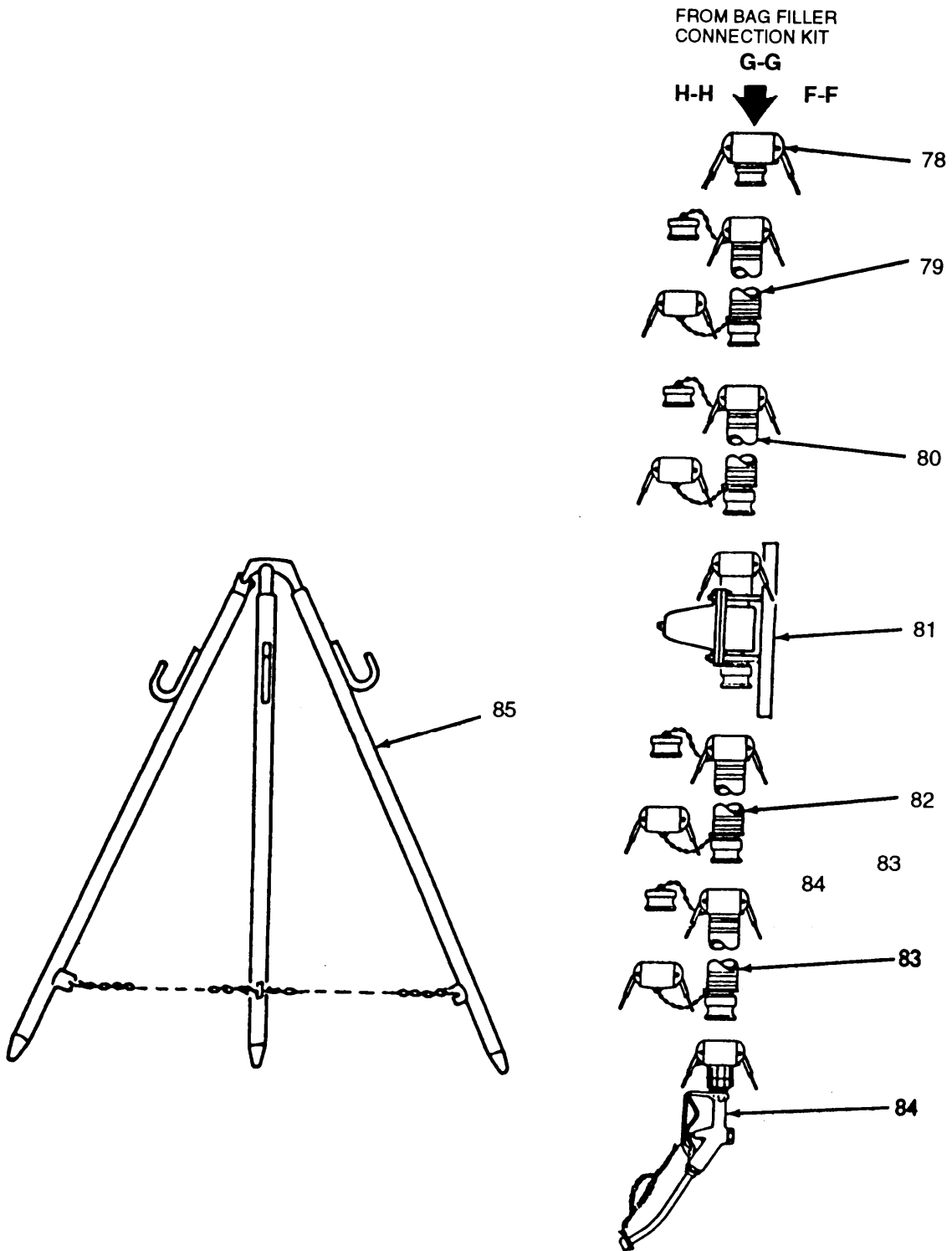
2.11 ASSEMBLY AND PREPARATION FOR USE - continued



Hose and Nozzle Kit

j. Final Assembly and Inspection.

- (1) Make sure all coupled connections are securely locked.
- (2) Make sure caps or plugs are installed in all open fittings and hoses.
- (3) Make sure discharge and suction hoses are not kinked.
- (4) Verify that all gate valves are closed.

2.12 OPERATION.

Operation of the 40K Water Distribution System is performed in two modes, fill and discharge. In the fill mode, water is pumped to and stored in the 20,000 gallon tanks. In the discharge mode, water is taken from the storage tanks and supplied to the distribution points. The system can operate in both fill mode and discharge mode at the same time.

a. Fill Mode.

- (1) Open gate valves V1, V2, V3 and V6,

NOTE

Water tanks may be filled separately by closing either gate valve V3 or V6.

- (2) Start and operate 125 GPM pump located at water source (refer to TM 5-4320-304-14 or TM 10-4320-309-14).
- (3) Allow water to flow into water tank(s) until full, or required amount is stored.
- (4) Shut down 125 GPM pump located at water source (refer to TM 5-4320-304-14 or TM 10-4320-309-14).
- (5) Close gate valves V1, V2, V3 and V6.

b. Discharge Mode.

NOTE

Water tanks may be discharged separately by closing either gate valve V4 or V5.

- (1) Open gate valve V4 and V5.
- (2) If 125 GPM pump only will be used for discharge, open gate valves V8 and V10. If 350 GPM pump only will be used for discharge, open gate valves V7 and V9. If both 125 and 350 GPM pumps will be used for discharge, open gate valves V7, V8, V9 and V10.
- (3) Start and operate 125 GPM pump and/or 350 GPM pump (refer to TM 5-4320-304-14, TM 10-4320-309-14 or TM5-4320-226-14 as applicable).
- (4) Start and operate hypochlorination unit (Refer to TM 5-4610-233-13&P).
- (5) Discharge water from hose connection kit by opening gate valves V11 through V18, as required.
- (6) Discharge water from hose nozzle connection kit by opening valves V19, V20, V21, or V22 and squeezing control handles on distribution nozzles.
- (7) Discharge water from bag filler connections by opening gate valves V23, V24, or V25 and squeezing control handles on distribution nozzles.
- (8) When discharge operation is complete, shutdown 125 and/or 350 GPM pumps (refer to TM 5-4320-304-14, TM 10-4320-309-14 or TM 5-4320-226-14 as applicable).
- (9) Close all gate valves opened during operation.
- (10) Shutdown hypochlorination unit (refer to TM 5-4610-233-13&P).

2.12 OPERATION - continued

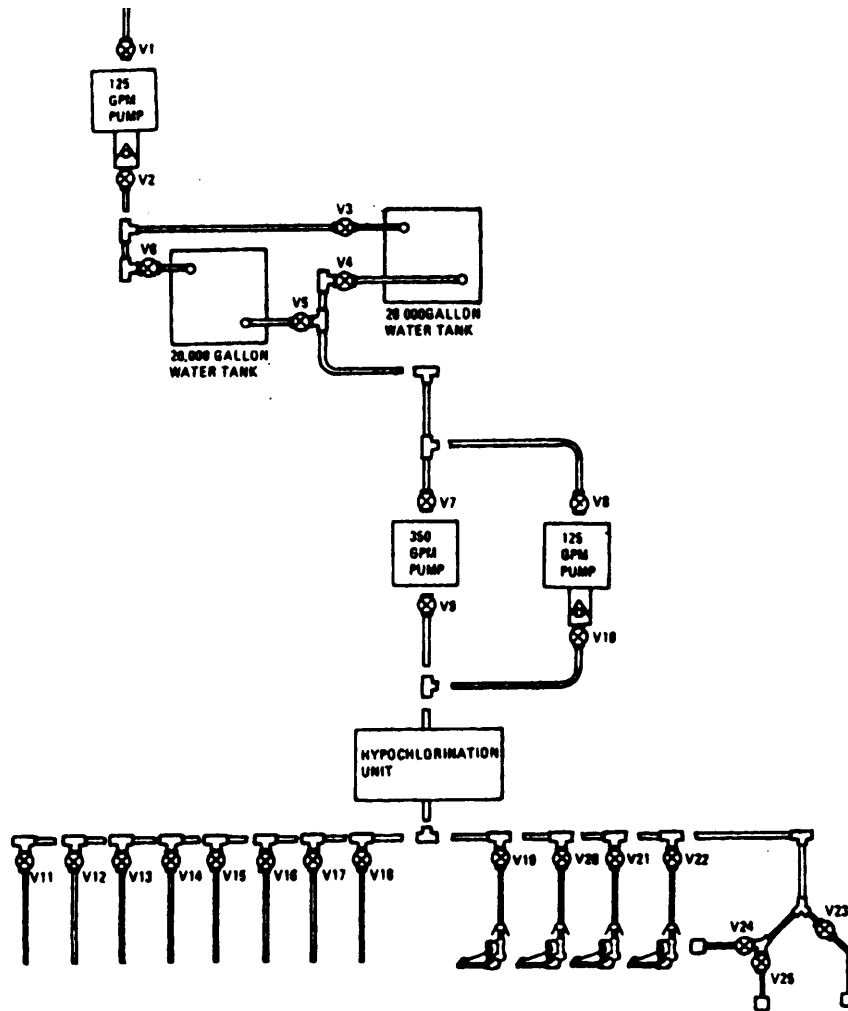

40K Water Distribution System Operation

2.13 PREPARATION FOR MOVEMENT

Warning

To prevent contamination of water system components, keep dirt mud, sand, and debris from entering open couplings during disassembly.

- a. Disassemble Hose and Nozzle Kit.
 - (1) Disconnect all distribution nozzles, discharge hoses, reducers, and regulator from bag filler connection kit.
 - (2) Drain water from all components and allow to dry. Install protective caps and plugs.
 - (3) Fold nozzle stands.
- b. Disassemble Bag Filler Connection Kit.
 - (1) Disconnect all discharge hoses, gate valves, tees, Wyes and reducers from hose nozzle connection kit.
 - (2) Drain water from all components and allow to dry. Install protective caps and plugs.
- c. Disassemble Hose Nozzle Connection Kit.
 - (1) Disconnect all discharge hoses, gate valves, tees, distribution nozzles and reducers from 350 GPM pump connection kit.
 - (2) Drain water from all components and allow to dry. Install protective caps and plugs.
 - (3) Fold nozzle stands,
- d. Disassemble Hose Connection Kit.
 - (1) Disconnect all discharge hoses, gate valves, tees, and reducers from 350 GPM pump connection kit.
 - (2) Drain water from all components and allow to dry. Install protective caps and plugs.
 - (3) Fold nozzle stands.
- e. Disassemble 125 GPM Pump Connection Kit.
 - (1) Disconnect all discharge hoses, gate valves, check valve, reducers and 125 GPM pump from 350 GPM pump connection kit.
 - (2) Drain water from all components and allow to dry. Install protective caps and plugs.
 - (3) Prepare 125 GPM pump for movement in accordance with TM 5-4320-304-14 or TM 10-4320-309-14.
- f. Disassemble 350 GPM Pump Connection.
 - (1) Disconnect all suction hoses, discharge hoses, tees, gate valve sand hypochlorination unit from dual tank connection kit.
 - (2) Drain water from all components and allow to dry. Install protective caps and plugs,
 - (3) Prepare hypochlorination trait for shipment in accordance with TM 5-4610-233-13&P.
 - (4) Prepare 350 GPM pump for movement in accordance with TM 5-4320-226-14.

2.13 PREPARATION FOR MOVEMENT - continued.

g. Disassemble Dual Tank Connection Kit.

- (1) Disconnect all suction hoses, discharge hoses, tees, and gate valves from water tanks and 125 GPM pump (source) connection kit.
- (2) Drain water from all components and allow to dry, Install protective caps and plugs.
- (3) Prepare water tanks for movement in accordance with TM 5-5430-226-12.

h. Disassemble 125 GPM Pump Connection Kit.

- (1) Disconnect all discharge hoses, gate valves, check valve, reducers and 125 GPM pump from water source.
- (2) Drain water from all components and allow to dry. Install protective caps and plugs.
- (3) Repair 125 GPM Pump for movement in accordance with TM 5-4320-304-14 or TM 10-4320-309-14.

2.14 DECALS AND INSTRUCTION PLATES.

Instruction plates are used on the 40K Water Distribution System to advise the operator of proper operating procedures. Stencils provide additional operating information and cautions to be observed during use of the equipment. Decals and instruction plates appear on major assemblies of the 40K water system.

- a. For decals and instruction plates on the 350 GPM pump, refer to TM 5-4320-226-14.
- b. For decals and instruction plates on the 125 GPM pump, refer to TM 5-4320-304-14 or TM 10-4320-309-14.
- c. For decals and instruction plates on the 20,000 gallon collapsible fabric tanks, refer to TM 5-5430-226-12.
- d. For decals and instruction plates on the hypochlorination unit, refer to TM 5-4610-233-13&P.
- e. The following illustration shows decals and instruction plates on the water tank chest.

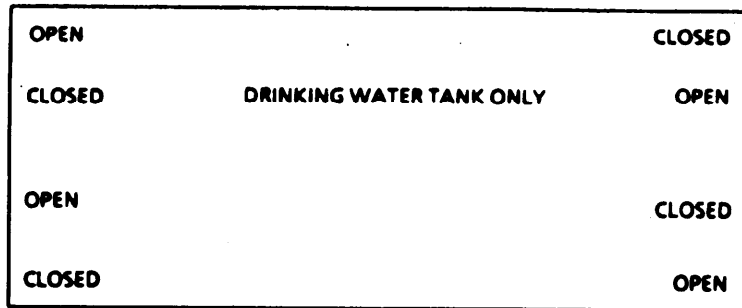

APPROX TARE WT 850LBS
 APPROX GROSS WT 2200LBS

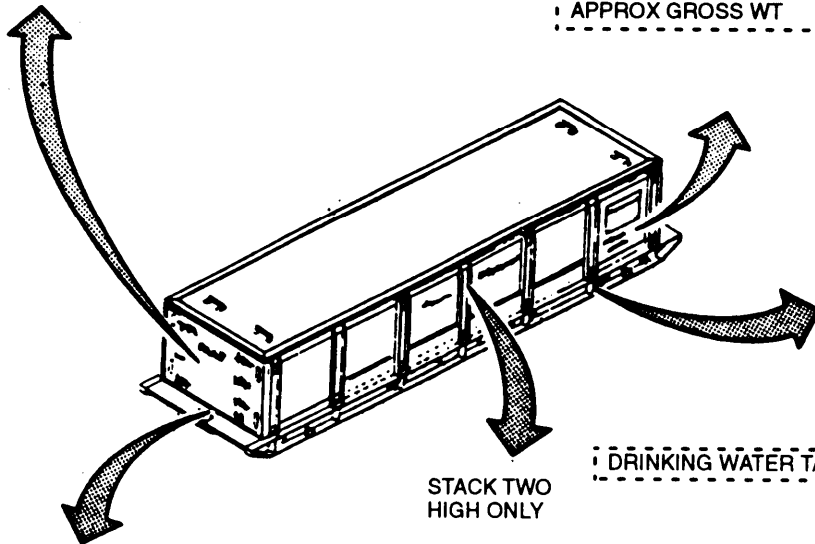

ENGINEERED AIR SYSTEM, INC.
 ST. LOUIS, MO 63132

NOMENCLATURE
 CHEST, COLLAPSIBLE WATER TANK

PART NUMBER SERIAL NO.

NATIONAL STOCK NO. CONTRACT NO.

U.S. 22068-1

Water Tank Chest Decals

Section IV. OPERATION UNDER UNUSUAL CONDITIONS

	Page
Operation In Extreme Cold	2-40
Operation In Extreme Heat	2-40
Operation In Dusty Or Sandy Areas	2-40

2.15 OPERATION IN EXTREME COLD.

Observe the following precautions when operating the 40K water distribution system in extremecold:

- a. When not in use, store water hoses and tanks in a heated area to avoid freezing.
- b. Remove snow, sleet or ice from quick disconnect couplings before making connections.
- c. Remove snow, sleet or ice from water tanks. Be careful to prevent cracking tanks if frozen.
- d. Wear arctic mittens when handling hardware. Change mittens if they get wet.
- e. Avoid unnecessary folding, unfolding or rolling of tank in freezing temperatures. Cracks can develop in tank fabric.
- f. When possible, set up and operate water tank from a heated shelter.
- g. Refer to TM 5-4320-226-14 for operating the 350 GPM pump under arctic conditions.
- h. Refer to TM 5-4320-304-14 or TM 10-4320-309-14 for operating the 125 GPM pump under arctic conditions.
- i. Refer to TM5-4610-233-13&P for operating the hypochlorination unit under arctic conditions.
- j. Refer to TM5-5430-226-12 For operating the water tanks under arctic conditions.

2.16 OPERATION IN EXTREME HEAT.

Observe the following precautions when operating the 40K water distribution system in extreme heat:

- a. Protect water tanks and hoses from extreme heat by covering with tarp. Set up tank in shaded area or construct a sun block.
- b. Ventilate area around water tanks. Make sure air flow can circulate freely around tanks.
- c. Avoid unnecessary folding, unfolding or rolling of empty water tanks and hoses. Do not store unused tank in direct sunlight.
- d. Refer to TM 5-4320-226-14 for operating the 350 GPM pump in extreme heat.
- e. Refer to TM 5-4320-304-14 or TM 10-4320-309-14 for operating the 125 GPM pump in extreme heat.
- f. Refer to TM 5-4610-233-13&P for operating the hypochlorination unit in extreme heat.
- g. Refer to TM5-5430-226-12 for operating the water tanks under in extreme heat.

2.17 OPERATION IN DUSTY OR SANDY AREAS.

Observe the following precautions when operating the water tank in dusty or sandy areas:

- a. Keep dust caps in place on fittings and couplings until ready for use.
- b. Carefully inspect coupling gaskets before connecting fittings. Remove all dirt, sand and debris before making connections.

- c. Refer to TM 5-4320-226-14 for operating the 350 GPM pump in dusty or sandy areas.
- d. Refer to TM 5-4320-304-14 or TM 10-4320-309-14 for operating the 125 GPM pump in dusty or sandy areas.
- e. Refer to TM 5-4610-233-13&P for operating the hypochlorination unit in dusty or sandy areas.
- f. Refer to TM 5-5430-226-12 for operating the water tanks under in dusty or sandy areas.

**CHAPTER 3
OPERATOR MAINTENANCE**

Section I. LUBRICATION INSTRUCTIONS

Lubrication of the 40K water distribution system is limited to the 125 and 350 GPM pump assemblies. Both pump assemblies consist of an engine and water pump. The water pumps uses prelubricated sealed ball bearings that require no lubrication. For lubrication of the engine used on the 125 GPM pump, refer to TM 5-4320-304-14 or TM 10-4320-309-14. For lubrication of the engine used on the 350 GPM pump, refer to LO 5-4320-226-12 and TM 5-4320-226-14. For lubrication of the hypochlorination unit, refer to TM 5-4610-233-13&P. No lubrication of the 20K Gallon Fabric Collapsible Water Tank is required.

Section II. OPERATOR TROUBLESHOOTING PROCEDURES

Introduction.....	Page 1-1
Troubleshooting.....	1-1

3.1 INTRODUCTION.

- a. Table 3-1 lists the common malfunctions which you may find during operation or maintenance of the 40K Water Distribution System or its components. You should perform the tests/inspection and corrective actions in the order listed.
- b. This manual cannot list all malfunctions that may occur, nor all tests or inspections and corrective actions. If a malfunction is not listed or is not corrected by listed corrective actions, notify unit maintenance.

3.2 TROUBLESHOOTING.

- a. For troubleshooting malfunctions on the 350 GPM pump, refer to TM5-4320-226-14.
- b. For troubleshooting malfunctions on the 125 GPM pump, refer to TM 5-4320-304-14 or TM 10-4320-309-14.
- c. For troubleshooting malfunctions on the hypochlorination unit, refer to TM 5-4610-233-13&P.
- d. For troubleshooting malfunctions on the 20,000 gallon collapsible fabric tanks, refer to TM 5-4320-226-12.
- e. For all other malfunctions, refer to Table 3-1.

Table 3-1. Operator Troubleshooting.



Be sure to read ALL Warnings on front of manual before troubleshooting.

Malfunction
Test or Inspection
Corrective Action

1. NO WATER FLOW TO LOADING STATIONS.

Step 1. Check for kinked hoses.

 Straighten kinked hoses.

Table 3-1. Operator Troubleshooting. (cont.)

Malfunction	Test or Inspection	Corrective Action
	Step 2. Verify that gate valves from discharge pumps to loading stations are fully open.	Open gate valves as required.
	Step 3. Verify that gate valves from water source to discharge pumps are fully open.	Open gate valves as required.
	Step 4. Check water level in both water tanks.	If low or empty, fill water tanks.
	Step 5. Inspect for disconnected hoses.	If hoses are disconnected, shut down water pumps and reconnect hoses.
	Step 6. Inspect discharge and suction hoses for leaks and kinks.	Straighten kinked hoses. If hose(s) are kinking, notify unit maintenance.
	Step 7. Verify that hypochlorination unit valves are set correctly.	Set hypochlorination valves for operation (refer to TM 5-4610-233-13&P).

NOTE

If malfunction cannot be corrected, notify unit maintenance,

2. LOW WATER PRESSURE AT LOADING STATIONS.

- Step 1. Check for kinked, leaking, or disconnected hoses.
 - If hoses are disconnected, shut down water pumps and reconnect hose.
 - Straighten hoses, if kinked.
 - Notify unit maintenance if hose (s) leak.
- Step 2. Verify that gate valves from water tank to discharge pumps are fully open.
 - Open gate valves.
- Step 3. Verify that gate valves From discharge pumps to to distribution nozzles are fully open.
 - Open gate valves.
- Step 4. Check For open gate valves in hose connection kit. If ail hose connection kits are in use, water flow to distribution nozzles may decrease.
 - If hoses are not in use, close hose connection kit gate valves.
- Step 5. Check water level in water tanks.
 - If tank in use is low or empty, discharge water from other tank.
 - If both tanks are low or empty, refill water tanks.

Table 3-1. Operator Troubleshooting. (cont.)

Malfunction	Test or Inspection	Corrective Action
Step 6.	Inspect distribution nozzle control handle for damage. Verify that control handle works smoothly.	If control handle is damaged or sticks, notify unit maintenance.
Step 7.	Verify correct setting of hypochlorination unit manifold valve (refer to TM 5-4610-233-13&P).	
Step 8.	Check operation of 125 and/or 350 GPM water pumps.	Troubleshoot 125 GPM pump in accordance with TM 5-4320-304-14 or TM 10-4320-309-14. Troubleshoot 350 GPM pump in accordance with TM 5-4320-226-14.
Step 9.	Check pressure regulator in 350 GPM pump connection kit for leaks.	If pressure regulator leaks, notify unit maintenance.
NOTE If malfunction cannot be corrected, notify unit maintenance.		

Section III. OPERATOR MAINTENANCE PROCEDURES

Water System Component Maintenance.....	Page 3-3
3.3 <u>WATER SYSTEM COMPONENT MAINTENANCE.</u>	

Operator maintenance on the 40K Water Distribution System hoses, valves, couplings, and fittings is limited to daily inspections when the system is setup for use. Replacement of defective components requires the services of unit maintenance. Refer to the following manuals for additional operator maintenance requirements,

Component	Technical Manual
125 GPM Pump	TM 5-4320-304-14 or TM 10-4320-309-14
350 GPM Pump	TM 5-4320-226-14
20,000 Gallon Collapsible Fabric Tank	TM 5-5430-226-12
Hypochlorination Unit	TM 5-4610-233-13&P

**CHAPTER 4
UNIT MAINTENANCE**

Section I. REPAIR PARTS, SPECIAL TOOLS; TEST, MEASUREMENT AND DIAGNOSTIC EQUIPMENT (TMDE); AND SUPPORT EQUIPMENT

	Page
Common Tools And Equipment	4-1
Special Tools, TMDE, And Support Equipment	4-1
Repair Parts	4-1

4.1 COMMON TOOLS AND EQUIPMENT.

For authorized common tools and equipment refer to the Modified Table of Organizational and Equipment (MTOE) applicable to your unit.

4.2 SPECIAL TOOLS, TMDE, AND SUPPORT EQUIPMENT.

No special tools or equipment are required to maintain the 40K Water Distribution System.

4.3 REPAIR PARTS.

Repair parts are listed and illustrated in the repair parts and special tools list (TM 10-4610-234-23P) covering unit maintenance for this equipment.

Section II. SERVICE UPON RECEIPT

	Page
Checking Unpacked Equipment	4-4
Introduction	4-1
Site Selection	4-1
Unpacking	4-1

4.4 INTRODUCTION.

Most of the 40K Water Distribution System components are shipped in reusable wooden crates of various sizes. The 20K gallon collapsible fabric tanks supplied with this system are shipped in reusable water tank chests. Use care when uncrating equipment to avoid unnecessary damage to shipping crates. When uncrating equipment, keep in mind that the system is made up of different connection kits. This manual addresses installation and use of all connection kits, but you may not need all of these components to perform your mission. Your operating requirements will determine which connection Ids/components are needed to perform the mission.

4.5 SITE SELECTION.

- a. Site selection must consider where and in what configuration the water system will be used. Siting and installation will determine where the water tanks and water pumps must be setup.
- b. Site selected must be level and free of rocks, sticks, gravel, and debris.

4.6 UNPACKING.

NOTE

The water tank may be packed in a reusable container, wooden crate or cardboard box when received.

- a. 20K Gallon Collapsible Fabric Tanks. The 20K tanks are packaged in reusable tank chests. Two 50K water tank chests are supplied with each 40K Water Distribution System. One chest contains two 20K

water tanks, the other chest contains one spare 20K water tank and the accessories for all three tanks. Unpack the water tanks as follows:

- (1) Locate tank chest containing two water tanks.
- (2) Unfasten eight latches (5).

Warning

To prevent injury to personnel, two personnel are required to lift top cover from tank chest.

- (3) Lift top cover (1) from water tank chest.
- (4) Move four handles (7) to OPEN position. Remove end panel (8) from water tank chest.
- (5) Repeat step (4) for other end panel (8).

Warning

To prevent injury to personnel, two personnel are required to lift side panel from tank chest.

- (6) Unlatch four locking pins (6) and lift side panel (4) from skid (3).
- (7) Remove accessory components from water tank chest.
- (8) Lift divider pan (2) from skid (3).
- (9) Unfasten tie down strap (11).

Warning

To prevent injury to personnel and damage to equipment, hoist, crane or similar type equipment having a minimum lifting capacity of 750 pounds must be used to lift water tank from skid.

- (10) Connect ends of two hoisting straps (10) to hoist, crane or similar type equipment.
- (11) Lift water tank (9) from skid (3).
- (12) Repeat steps (9) through (11) for other water tank.

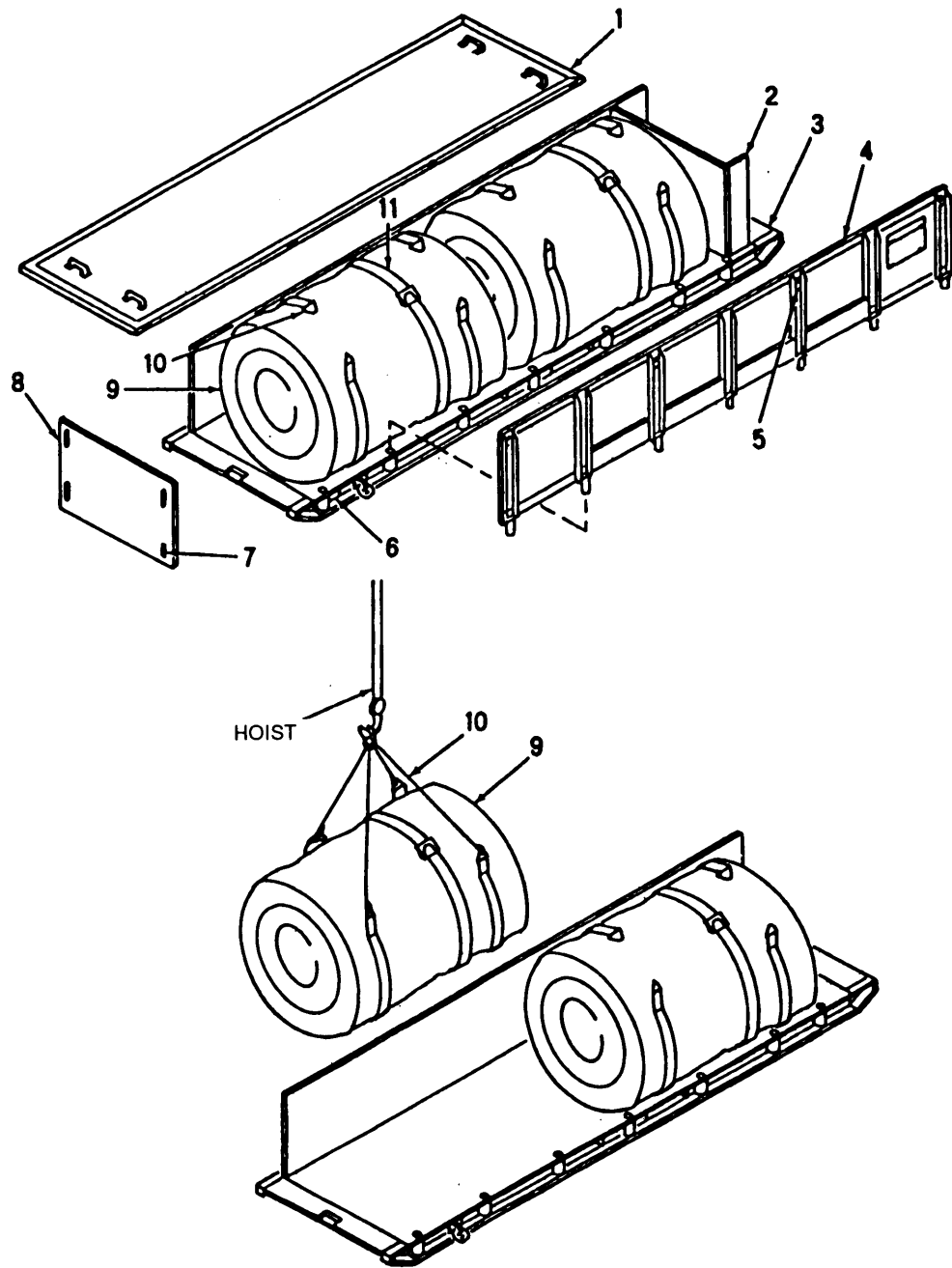

Water Tank Chest Maintenance

- b. Connection Kits. All water tank connection kits are supplied in reusable wooden packing crates. When unpacking, do not mix components from one kit with components of another kit.
 - (1) Cut banding straps from crate.
 - (2) Remove top from crate.
 - (3) Remove components from crate.
 - (4) Remove protective wrapping materials from components.
- c. 125 GPM Pump Assemblies. Refer to TM 5-4320-304-14 or TM 10-4320-309-14 for unpacking instructions.
- d. 350 GPM Pump Assemblies. Refer to TM 5-4320-226-14 for unpacking instructions.
- e. Hyppochlorination Unit. Refer to TM 5-4610-233-13&P for unpacking instructions.

4.7 CHECKING UNPACKED EQUIPMENT

- a. Inspect the equipment for damage incurred during shipment. If the equipment has been damaged, report the damage on SF 364, Report of Discrepancy.
- b. Inspect components to make sure they are in a serviceable condition.
- c. Check the equipment against the packing slip to see if the shipment is complete. Report all discrepancies in accordance with instructions of DA PAM 738-750.
- d. Check to see if equipment has been modified.
- e. Remove all protective compounds and covering such as wax paper, waterproof tape, and barrier material. Remove preservatives and greases from unpainted, threaded, or exposed surfaces.

Section III. UNIT PREVENTIVE MAINTENANCE CHECKS AND SERVICES

	Page
Preventive Maintenance Checks And Services (PMCS)	4-4

4.8 PREVENTIVE MAINTENANCE CHECKS AND SERVICES (PMCS)

- a. General. This section Contains the procedures and instructions necessary to perform unit PMCS. These services are to be performed by unit maintenance personnel with the assistance, where applicable, of the operator/crew. Your PMCS is performed to find and fix problems before they cause major damage to the equipment. Perform the PMCS in the order listed.
- b. PMCS Procedures. Refer to Table 4-1.
 - (1) Item Number Column. Checks and services are numbered in chronological order regardless of interval. This column is used as a source of item number for the "TM Number" column on DA Form 2404, Equipment Inspection and Maintenance Worksheet, in recording results of PMCS.
 - (2) Interval Column. The interval column tells you when to do a certain checker service. Unit PMCS on the water tank is performed quarterly.
 Quarterly = every 90 days (3 months)
 - (3) Item To Check/Service Column. This column lists the common name of the item to be inspected, such as "Gate Valve".
 - (4) Procedure Column. This column tells you how to do the required checks or services. Carefully follow these instructions. If you do not have the tools, or if the procedures tell you to, have direct support maintenance do the work.
 - (5) Not Mission Capable If Column. This column tells you when and why your equipment cannot be used.

- c. Prior to Storage or Shipment. A complete PMCS must be performed prior to storage or shipment of the water tank.

Table 4-1. Unit Preventive Maintenance Checks and Services.

Item No.	interval	Location	Procedure	Not Mission Capable If:
		Item To Check/ Service		
1	Quarterly	Discharge Hoses (all sizes)	a. Inspect for cuts, tears, and deep abrasions. b. Inspect couplings for cracks, broken locking arms, and missing gaskets. c. Inspect for missing dust cap red/or plug.	
2	Quarterly	Gate Valves (all sizes)	a. Inspect for loose, damaged or missing valve handle. b. Check for bent valve stem. c. Inspect for missing coupling gaskets. d. Inspect for broken coupling lock arms. e. Inspect for missing dust cap red/or plug. f. Inspect for loose or missing bolts and nuts.	
3	Quarterly	Tee Assemblies	a. Inspect fittings for cracks. b. Inspect couplings for damage. c. Inspect for missing dust cap and/or plug.	
4	Quarterly	Distribution Nozzles	a. Inspect for bent or broken control handle. b. Inspect for bent or broken nozzle tube,	
5	Quarterly	Water Pressure Regulator	a. Inspect regulator body for cracks. b. Inspect couplings for damage.	
6	Quarterly	Nozzle Stand	a. Inspect for bent, broken or cracked legs. b. Inspect for missing support chains.	

Table 4-1. Unit Preventive Maintenance Checks and Services. (cont.)

item No.	Interval	Location	Procedure	Not Mission Capable If:
		Item To Check/ Service		
7	Quarterly	Suction Hoses (all sizes)	a. inspect for cuts, tears and deep abrasions. b. Inspect for crushed or collapsed hose. c. Inspect coupling for cracks, broken locking arms, and missing gaskets. d. Inspect for missing dust cap and/air plug.	
8	Quarterly	Water Meter Assembly	a. Inspect meter cover for cracks. b. Inspect meter indicator dials for damage.	
9	Quarterly	Check Valve	Inspect check valve body for cracks.	
10	Quarterly	Water Tank Chest	Inspect for broken panels, cracks and broken latches.	
11	Quarterly	20K Water Tanks	Inspect water tanks in accordance with TM 5-5430-226-12.	
12	Quarterly	Hypochlorination Unit	Inspect hypochlorination unit in accordance with TM 5-4610-233-13&P.	
13	Quarterly	125 GPM Pump Assembly	Inspect 125 GPM pump in accordance with TM 5-4320-304-14 or TM 10-4320-309-14.	
14	Quarterly	350 GPM Pump Assembly	Inspect 350 GPM pump in accordance with TM 5-4320-226-14.	

Section IV. UNIT TROUBLESHOOTING PROCEDURES

Introduction	Page 4-6
Troubleshooting	4-6

4.9 INTRODUCTION.

- a. Table 4-2 lists the common malfunctions which you may find during operation or maintenance of the 40K Water Distribution System or its components. You should perform the tests/inspection and corrective actions in the order listed.
- b. This manual cannot list all malfunctions that may occur, nor all tests or inspections and corrective actions. If a malfunction is not listed or is not corrected by listed corrective actions, notify your supervisor.

4.10 TROUBLESHOOTING.

Refer to Table 4-2.

Table 4-2. Unit Troubleshooting.

Warning

Be sure to read ALL Warnings on front of manual before troubleshooting.

Malfunction
Test or Inspection
Corrective Action

1.2-INCH GATE VALVE LEAKS.
Step 1. Check for loose gland nut.

Tighten gland nut 1/4 turn.

Step 2. Inspect gate valve body for cracks.

Replace gate valve (refer to para. 4.14).

2.4-INCH GATE VALVE LEAKS.
Step 1. Check for loose gland nut.

Tighten gland nut 1/4 turn.

Step 2. Check for loose nuts at flanged coupling.

Tighten flanged coupling nuts and bolts (refer to para. 4.24).

Step 3. Check for damaged or missing coupling gaskets.

Replace gaskets (refer to para. 4.24).

Step 4. Check for damaged or missing flange gaskets.

Replace gaskets (refer to para. 4.24).

Step 5. Inspect gate valve body for cracks.

Replace gate valve (refer to para. 4.24).

3. DISCHARGE OR SUCTION HOSE LEAKS.
Step 1. Check for damaged or missing coupling gaskets.

Replace gaskets (refer to para. 4.13).

Step 2. Inspect hose for cracks, tears and punctures.

Replace hose (refer to para. 4.13).

Step 3. Inspect for cracked quick disconnect couplings.

Replace couplings (refer to para. 4.13).

Step 4. Inspect for loose or missing strap clamps.

Replace strap clamps (refer to para. 4.1 3).

4. CHECK VALVE LEAKS.
Step 1. Check for damaged or missing coupling gasket.

Replace gasket (refer to para. 4.28).

Step 2. Inspect for cracked quick disconnect couplings.

Replace couplings (refer to para. 4.28).

Table 4-2. Unit Troubleshooting. (cont.)

Malfunction	Test or Inspection	Corrective Action
5. CHECK VALVE STUCK CLOSED.		
	Step 1. Inspect valve for contaminants stuck in valve body.	Repair check valve (refer to para. 4.28).
	Step 2. Push on inlet side of check valve flapper. Flapper should open and close freely without binding or sticking.	Repair check valve (refer to para. 4.28).
6. TEE ASSEMBLY LEAKS.		
	Step 1. Check for damaged or missing coupling gaskets.	Replace gaskets (refer to para. 4.15).
	Step 2. Check for cracked quick disconnect couplings and/or tee body.	Replace tee assembly (refer to para. 4.15).
7. DISTRIBUTION NOZZLE(S) WILL NOT SHUT OFF WHEN CONTROL LEVER IS RELEASED.		
	Check operation of distribution nozzle(s). Control stem should extend when control lever is released.	
	Replace distribution nozzle(s) (refer to para. 4.16 and/or 4.20).	
8. WATER PRESSURE REGULATOR LEAKS.		
	Step 1. Check for loose bolts on regulator body.	Tighten bolts.
	Step 2. Check for damaged or missing coupling gaskets.	Replace water pressure regulator (refer to para. 4.17).
	Step 3. Check for cracked quick disconnect coupling.	Replace water pressure regulator (refer to para. 4.17).
9. WATER PRESSURE AT HOSE AND NOZZLE KIT IS TOO HIGH OR TOO LOW.		
	Check setting of pressure regulator.	
	Adjust pressure regulator (refer to para. 4.17).	
	If regulator cannot be adjusted, replace regulator (refer to para. 4.17).	
10. WATER METER LEAKS.		
	Step 1. Check for damaged or missing coupling gaskets.	Replace gaskets (refer to para. 4.25).
	Step 2. Check for cracked quick disconnect coupling.	Replace couplings (refer to para. 4.25).
NOTE		
If leak cannot be corrected, replace water meter.		

Section V. UNIT MAINTENANCE PROCEDURES

Procedure	Page
125 Gpm Connection Kit Maintenance	4-36.4 ■
125 Gpm Pumping Assembly Maintenance	4-41
20,000 Gallon Collapsible Fabric Tank Maintenance	4-44
350 Gpm Pumping Assembly Maintenance	4-36.4 ■
350 Gpm Pump Connection Kit Maintenance	4-27
Accessory Kit Maintenance	4-44
Bag Filler Connection Kit Maintenance	4-9
Check Valve Assembly Maintenance	4-37
Discharge And Suction Hose Assembly Maintenance	4-10
Distribution Nozzle (1-1/2 inch) Assembly Maintenance	4-27
Distribution Nozzle (1-inch) Assembly Maintenance	4-22
Dual Tank Connection Kit Maintenance	4-41
Gate Valve Assembly (4-inch) Maintenance	4-28
Gate Valve Assembly (2-inch) Maintenance	4-15
General	4-9
Hose Connection Kit (2-inch) Maintenance	4-27
Hose Nozzle Kit Maintenance	4-27
Hypochlorination Unit Maintenance	4-27
Nozzle Stand Assembly Maintenance	4-25
Tee and Gate Valve Assembly Maintenance	4-42
Tee Assembly Maintenance	4-18
Water Meter Assembly Maintenance (Model WSDS40K)	4-32 ■
Water Meter Assembly Maintenance (Model 40KWSDS)	4-36
Water Pressure Regulator Assembly Maintenance	4-23
Water Tank Chest Maintenance	4-45

4.11 GENERAL.

This section contains procedures for performing unit level maintenance on the 40K Water Storage and Distribution System. Refer to applicable technical manuals for unit maintenance on the following equipment

Equipment	Technical Manual
Hypochlorination Unit	TM 5-4610-233-13&P
125 GPM Pump	TM 5-4320-304-14 or TM 10-4320-309-14
350 GPM Pump	TM 5-4320-226-14
20,000 Gallon Collapsible Fabric Tank	TM 5-5430-226-12

4.12 BAG FILLER CONNECTION KIT MAINTENANCE.

The bag filler connection kit consists of the components listed below. Refer to the following paragraphs for applicable maintenance procedures.

Procedure	Para.
1-Inch Distribution Nozzle Maintenance	4.16
2-Inch Gate Valve Assembly Maintenance	4.14
Discharge Hose Maintenance	4.13
Nozzle Stand Assembly Maintenance	4.18
Tee Assembly Maintenance	4.15
Water Pressure Regulator Assembly Maintenance	4.17

4.13 DISCHARGE AND SUCTION HOSE ASSEMBLY MAINTENANCE

NOTE

The following procedures apply to all sizes and lengths of discharge and suction hoses used in this system.

-
- | | | |
|------------------------|----------------|-----------------|
| This task consists of: | a. Removal | e. Repair |
| | b. Disassembly | f. Assembly |
| | c. Cleaning | g. Installation |
| | d. Inspection | |
-

INITIAL SET-UP:

Tools:

- Metal Strapping Hand Sealer (from 40K Water Distribution System Accessory Kit)
- Tool Kit, General Mechanics, Automotive (Appendix B, Sec. III, Item 1)
- Vice (Appendix B, Sec. III, Item 2)

Materials/Parts Required:

- Detergent, General Purpose (Item 1, Appendix D)
- Rag, Wiping (Item 2, Appendix D)

NOTE

Determine additional materials required by using the following table.

Hose Size	Coupling Gasket	Seal	Strapping
1-inch	MS27030-3 (2)	C254 (4)	C204
1 1/2-inch	MS27030-5 (2)	C254 (4)	C204
2-inch	MS27030-6 (2)	C254 (4)	C204
4-inch	MS27030-9 (2)	C256 (4)	C206

- a. Removal. Disconnect discharge or suction hose assembly from water system (refer to para 2.10 to disconnect couplings).
- b. Disassembly.

NOTE

Disassemble hoses only to the level required to make repairs.

- (1) Disconnect split ring (15) from female coupling (2). Remove dust plug (14).
- (2) Disconnect split ring (10) from male coupling (9). Remove dust cap (11).
- (3) Remove gasket (13) from dust cap (11).
- (4) Remove gasket (1) from female coupling (2).
- (5) Cut strap clamps (4 and 5) from hose (6). Pull female coupling (2) from hose.
- (6) Cut strap clamps (7 and 8) from hose (6). Pull male coupling (9) from hose.
- c. Cleaning.

- (1) Clean all components with clean water and detergent.
 - (2) Rinse components in clean water and dry with wiping rag.
- d. **Inspection.**
- (1) Inspect female coupling (2) and dust cap(11) for cracks, corrosion, and damaged locking arms (3 and 12).
 - (2) Inspect male coupling (9) and dust plug (14) for cracks and corrosion.
 - (3) Inspect hose (6) for cuts, tears, punctures, delamination and peeling.
- e. **Repair.** Replace damaged components. Do not reuse coupling gaskets or strap clamps.

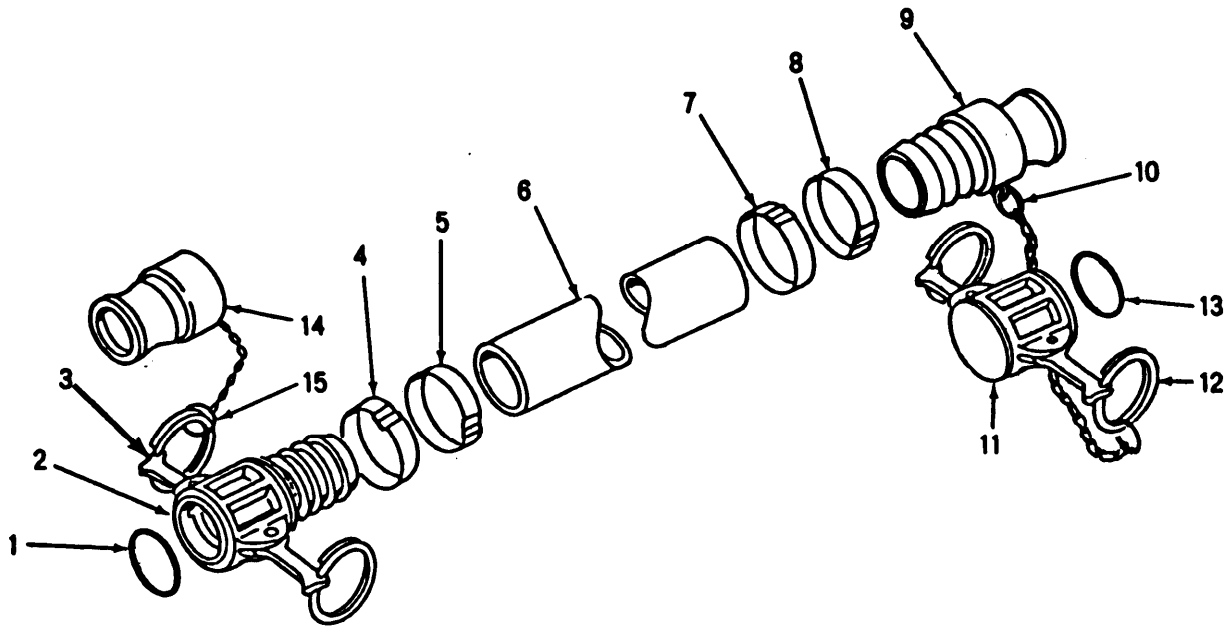

Discharge and Suction Hose Assemblies

f. **Assembly.**

- (1) Push male coupling (9) and female coupling (2) into hose (6).
- (2) Install strap clamp (4) as follows:

NOTE

Rolls of strapping and clamp seals are supplied in 40K Water Distribution Accessory Kit.

- (a) Cut a piece of strapping (23) 36 inches long
- (b) Slide seal (16) onto strapping (23) as shown. Bend end of strapping under seal.
- (c) Wrap other end of strapping (23) around hose (22) and through seal (16). Position strapping on hose about 1 inch from coupling.
- (d) Wrap another loop of strapping (23) around hose (22) and through seal (16).
- (e) Position strapping (23) in slots of strapping tool (19). Tool nose (20) should fit snug against seal (16).
- (f) Apply pressure to gripper lever(18) and turn handle(17) until strapping (23) is snug. Tool will lock in place when correct tension is applied. Reposition tool as required.

4.13 DISCHARGE AND SUCTION HOSE ASSEMBLY MAINTENANCE - continued



Do not overtighten strapping when turning handle.

- (g) Turn handle (17) clockwise to tighten strapping (23). Continue turning handle until strapping stops moving through seal (16).



Strapping may break if operator does not release tension on handle when bending over seal.

- (h) While reversing handle (17) 3/4 turn, roll tool (19) to opposite side of seal (16). (This will bend strapping and prevent it from slipping through seal when tool is removed.)
 - (i) Pull cutting handle (21) on tool to cut strapping (23).
 - (j) Remove tool (19) while holding strapping stub down on seal (16) with thumb.
 - (k) Clinch end of strapping (23) by hammering down tabs of seal (16) over strapping stub.
- (3) Repeat steps (a) through (k) for three other strap clamps (5,7, and 8).

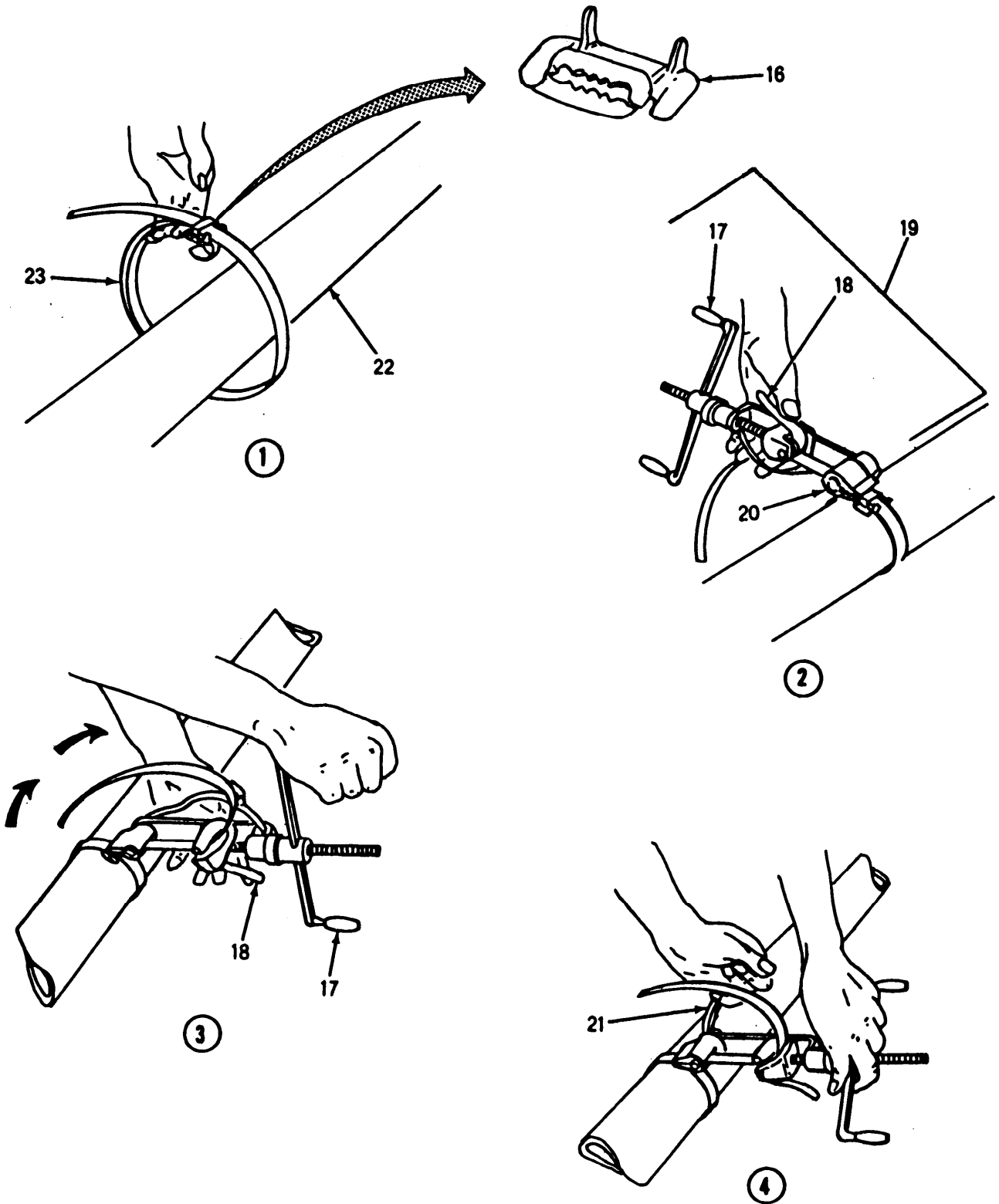

Strap Clamp Installation

4.13 DISCHARGE AND SUCTION HOSE ASSEMBLY MAINTENANCE - continued

NOTE

Ensure gasket is fully seated in groove of coupling/dust cap.

(4) Install gasket (1) in female coupling (2).

(5) Install gasket (13) in dust cap (11).

(6) Connect split ring (10) to male coupling (9). Install dust cap (11) on coupling.

(7) Connect split ring (15) to female coupling (2). Install dust plug (14) on coupling.

g. Installation. Connect discharge or suction hose assembly to water system (refer to para. 2.10 to connect couplings).

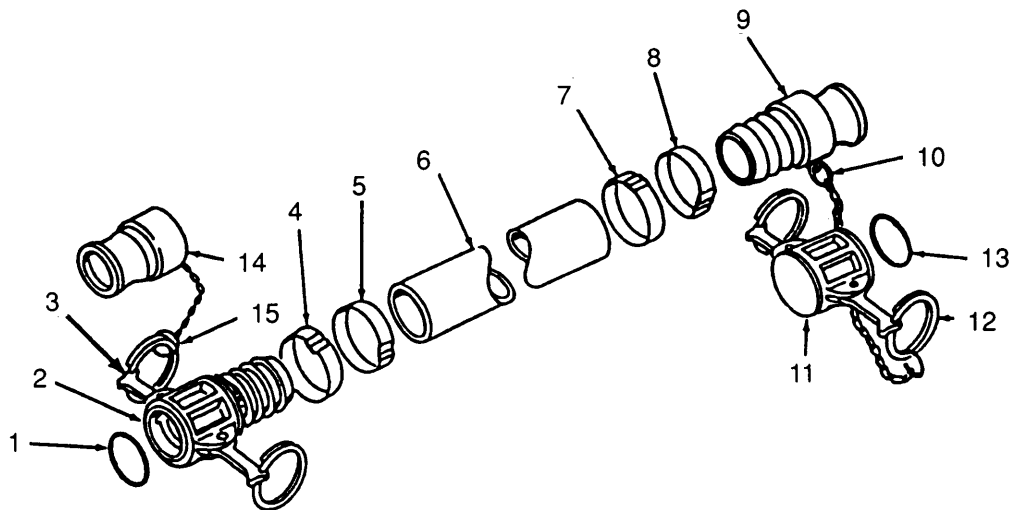

Discharge Hose Assembly

4.14 GATE VALVE ASSEMBLY (2-INCH) MAINTENANCE (MODELS WSDS40K & 40KWSDS)

This task consists of:

- | | |
|----------------|-----------------|
| a. Removal | e. Repair |
| b. Disassembly | f. Assembly |
| c. Cleaning | g. Installation |
| d. Inspection | |

INITIAL SET-UP:

Tools:

- Tool Kit, General Mechanics, Automotive (Appendix B, Sec. III, item 1)
- Vice (Appendix B, Sec. III, Item 2)
- Pipe Wrench (From 40K System Accessory Kit)

Materials/Parts Required:

- Detergent, General Purpose (Item 1, Appendix D)
- Rag, Wiping (Item 2, Appendix D)
- Tape, Anti-seize (Item 3, Appendix D)
- Coupling Gasket (1) - MS27030-6
- Packing Gland - BV1182-8

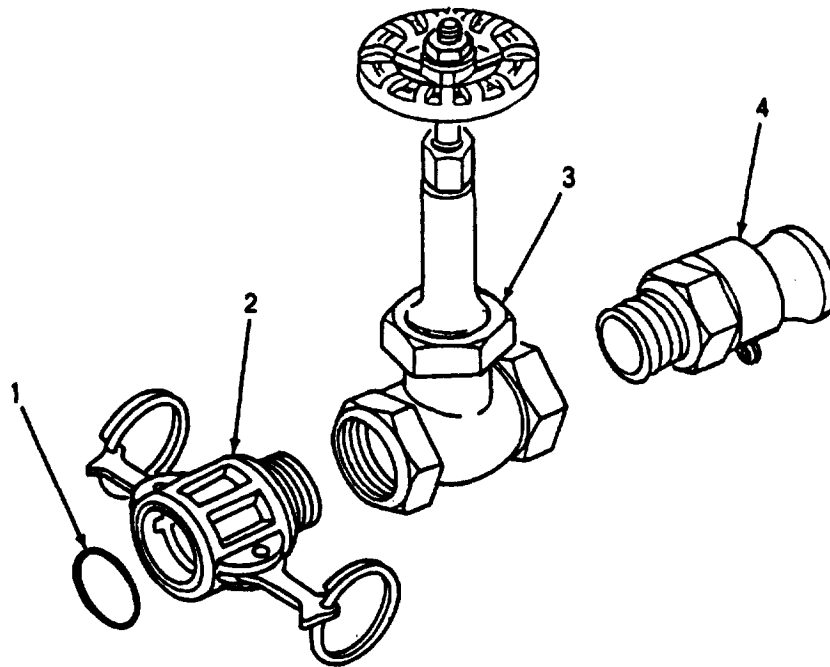

Gate Valve Assembly (2-inch)

- a. Removal. Disconnect gate valve assembly from water system (refer to para 2.10 to disconnect couplings).

4.14 GATE VALVE ASSEMBLY (2-INCH) MAINTENANCE (MODELS WSDS40K & 40KWSDS) (continued)

b. Disassembly.

- (1) Clamp gate valve body (3) in vise.
- (2) Using pipe wrench, unscrew reducer (4) from valve body (3).
- (3) Using pipe wrench, unscrew female coupler (2) from valve body (3).
- (4) Remove gasket (1) from female coupler (2).
- (5) Turn handwheel (6) fully clockwise to close valve.
- (6) Remove handwheel nut (5) and handwheel (6) from stem (12).
- (7) Using pipe wrench, remove bonnet ring (11) from valve body (3). Lift bonnet (10) and attached parts from valve body.
- (8) Remove disc (13) from stem (12).
- (9) Unscrew packing nut (7) from bonnet (10).
- (10) Remove packing gland (8) and packing (9) from bonnet (10).
- (11) Unscrew stem (12) from bonnet (10).

c. Cleaning.

- (1) Clean all components with clean water and detergent.
- (2) Rinse components in clean water and dry with wiping rag.

d. Inspection.

- (1) Inspect valve body (3) for cracks and stripped or damaged threads.
- (2) Inspect disc (13) for cuts or scratches across sealing surfaces.
- (3) Inspect bonnet (10) for cracks and stripped threads.
- (4) Inspect stem (12) for stripped, galled or damaged threads.
- (5) Inspect female coupler (2) for cracks, broken lock arms and damaged threads.
- (6) Inspect reducer (4) for cracks and damaged threads.

e. Repair. Replace all defective parts. Do not reuse packing,

f. Assembly.

- (1) Screw stem (12) into bonnet (10).
- (2) Install new packing (9) and packing gland (8) in bonnet (10).
- (3) Screw packing nut (7) onto bonnet (10) finger tight.
- (4) Install disc (13) on stem (12).
- (5) Lower bonnet (10) and attached parts onto valve body (3). Install bonnet ring (11) on valve body (3). Tighten packing nut (7).
- (6) Install handwheel (6) and handwheel nut (5) on stem (12).

NOTE

Ensure gasket is fully seated in groove of coupler.

- (7) Install gasket (1) in female coupler (2).
- (8) Apply anti-seize tape to threads of female coupler (2). Using pipe wrench, screw coupler into valve body (3).

(9) Apply anti-seize tape to threads of reducer (4). Using pipe wrench, screw reducer into valve body (3).

g. Installation. Connect gate valve assembly to water system (refer to para. 2.10 to connect couplings).

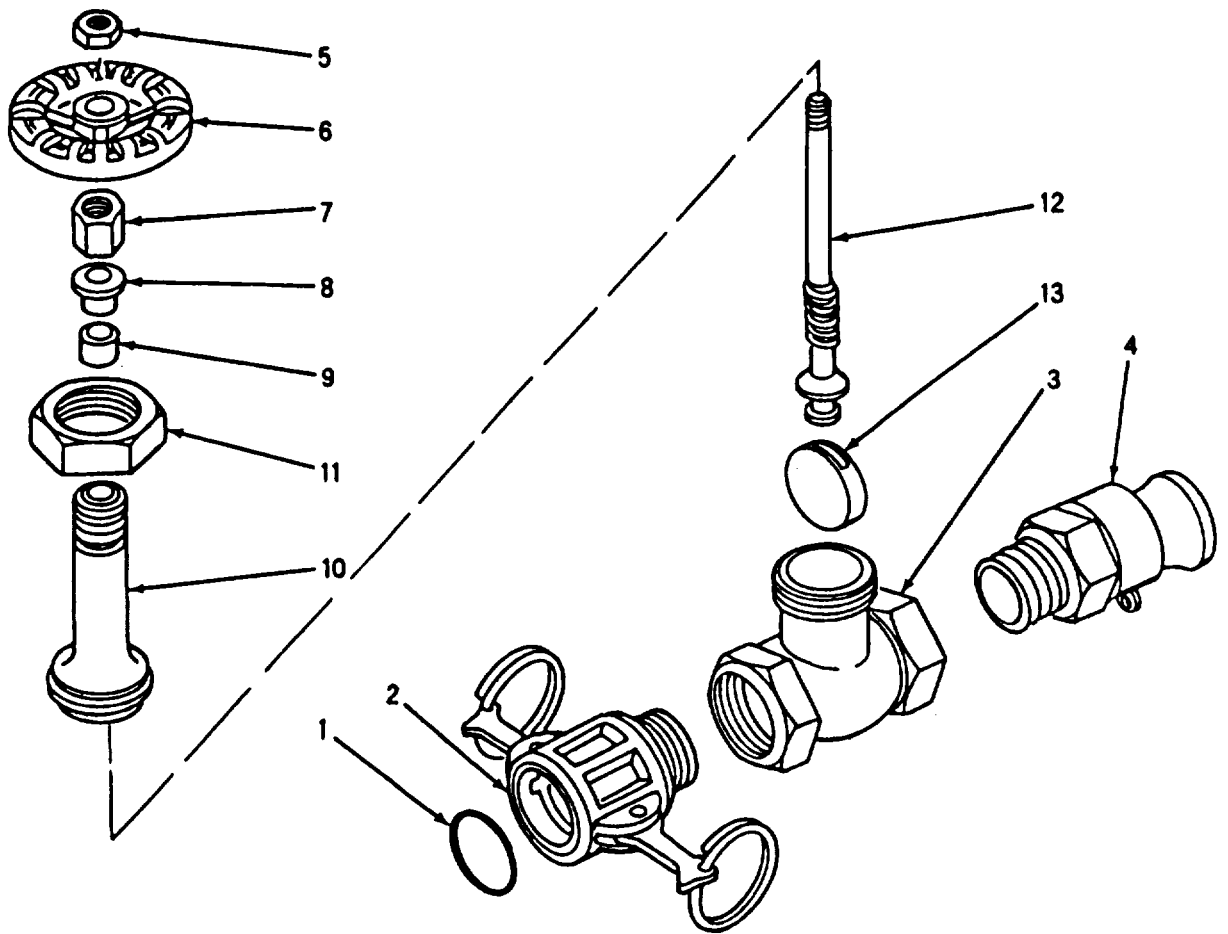

Gate Valve Assembly (2-inch) (Models WSDS40K & 40KWSDS)

4.14.1 GATE VALVE ASSEMBLY (2-INCH) MAINTENANCE (MODEL ALP9440)

This task consists of	a. Removal b. Disassembly c. Cleaning d. Inspection	e. Repair f. Assembly g. Installation
-----------------------	--	---

INITIAL SET-UP:

Tools:

Tool Kit, General Mechanics, Automotive (Appendix B, Sec. III, Item 1)

Materials/Parts Required:

Detergent, General Purpose (Appendix D, Item 1)
Rag, Wiping (Appendix D, item 2)

- a. Removal Disconnect valve assembly from water system (refer to para. 2.10 to disconnect couplings).
- b. Disassembly.
 - (1) Clamp gate valve in vice.
 - (2) Remove cap (1) from male coupler (7).
 - (3) Remove chain (2) from cap (1) and male coupler (7).
 - (4) Remove plug (3) from female coupler (5).
 - (5) Remove chain (4) from plug (3) and female coupler (5).
 - (6) Using pipe wrench, unscrew male coupler (7) from valve body (19).
 - (7) Using pipe wrench, unscrew female coupler (5) from valve body (19).
 - (8) Remove gasket (6) from female coupler (5).
 - (9) Remove gasket (8) from cap (1).
 - (10) Shut valve completely.
 - (11) Remove handwheel nut (9).
 - (12) Remove label plate (10) and handwheel (11).
 - (13) Unscrew and remove packing gland nut (12).
 - (14) Remove packing gland follower (13).
 - (15) Remove packing (14).
 - (16) Unscrew and remove stuffing box (15).
 - (17) Unscrew bonnet (16) and remove it and attaching pieces.

NOTE

Stem (17) has left-handed threads.

- (18) Unscrew disc (18) from stem (17).
- (19) Remove stem (17) from bonnet (16).

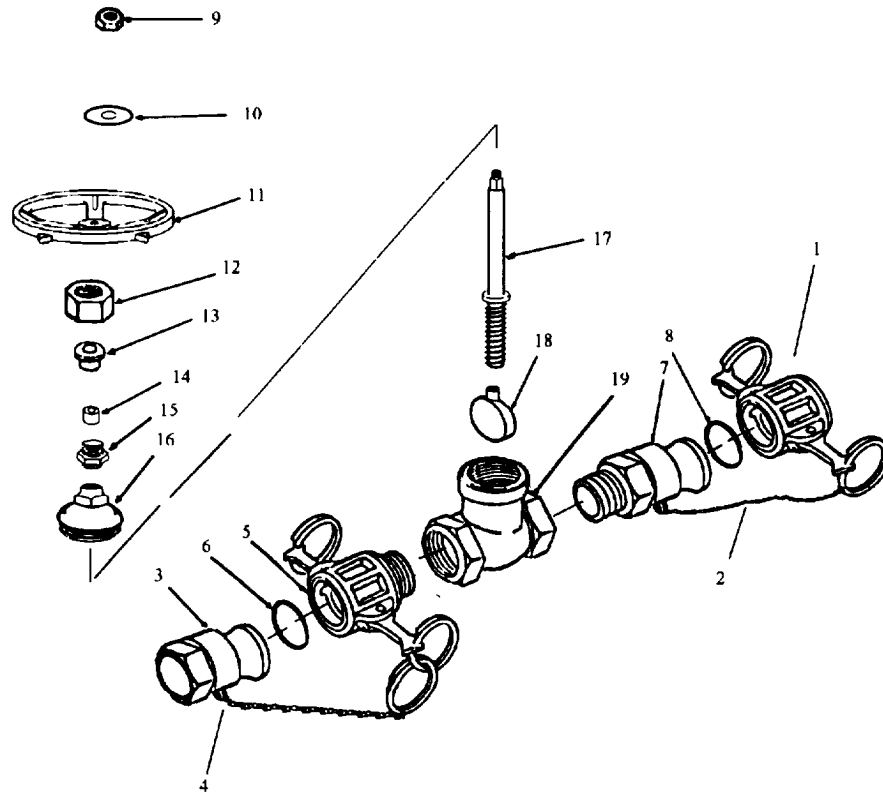

Gate Valve Assembly (2-inch)

c. Cleaning.

- (1) Clean all components with clean water and detergent.
- (2) Rinse components in clean water and dry with wiping rag.

d. Inspection.

- (1) Inspect valve body (19) for cracks and stripped or damaged threads.
- (2) Inspect disc (18) for cuts or scratches across sealing surfaces, and damaged threads.
- (3) Inspect bonnet (16) for cracks and stripped threads.
- (4) Inspect stem (17) for stripped, galled, or damaged threads.
- (5) Inspect female coupler (5) for cracks, broken lock arms, and damaged threads.
- (6) Inspect male coupler (7) for cracks and damaged threads.
- (7) Inspect cap (1) and plug (3) for cracks and broken lock arms.
- (8) Inspect chains (2 and 4) for cracked or broken links.

e. Repair.

- (1) Replace all defective parts. Do not reuse packing (14).

4.14.1 **GATE VALVE ASSEMBLY (2-INCH) MAINTENANCE (MODEL ALP9440)**

Assembly.

- (1) Install stem (17) in bonnet (16).

NOTE

Stem (17) has left-handed threads.

- (2) Screw disc (18) onto stem (17) all the way, making sure not to tighten more than hand tight.
- (3) Screw bonnet (16) onto valve body (19).
- (4) Install stuffing box (15) into bonnet (16).
- (5) Install new packing (14).
- (6) Install packing gland follower (13).
- (7) Screw packing gland nut (12) onto stuffing box.
- (8) Install handwheel (11) and label plate (10).
- (9) Screw handwheel nut (9) onto stem (17).

NOTE

Make sure gasket (6) is fully seated in groove of female coupler (5).

- (10) Install gaskets (6 and 8) in female coupler (5) and cap (1) .
- (11) Apply anti-sieze tape to threads of female coupler (5).
- (12) Using pipe wrench, screw female coupler (5) into valve body (19).
- (13) Connect chain (4) to female coupler (5) and plug (3).
- (13) Apply anti-sieze tape to threads of male coupler (7).
- (14) Using pipe wrench, screw male coupler (7) into valve body (19).
- (15) Connect chain (2) to male coupler (7) and cap (1).

Installation.

- (1) Remove cap (1) from male coupler (7) and plug (3) from female coupler (5).
- (2) Connect gate valve assembly to water system (refer to para. 2.10 to connect couplings).

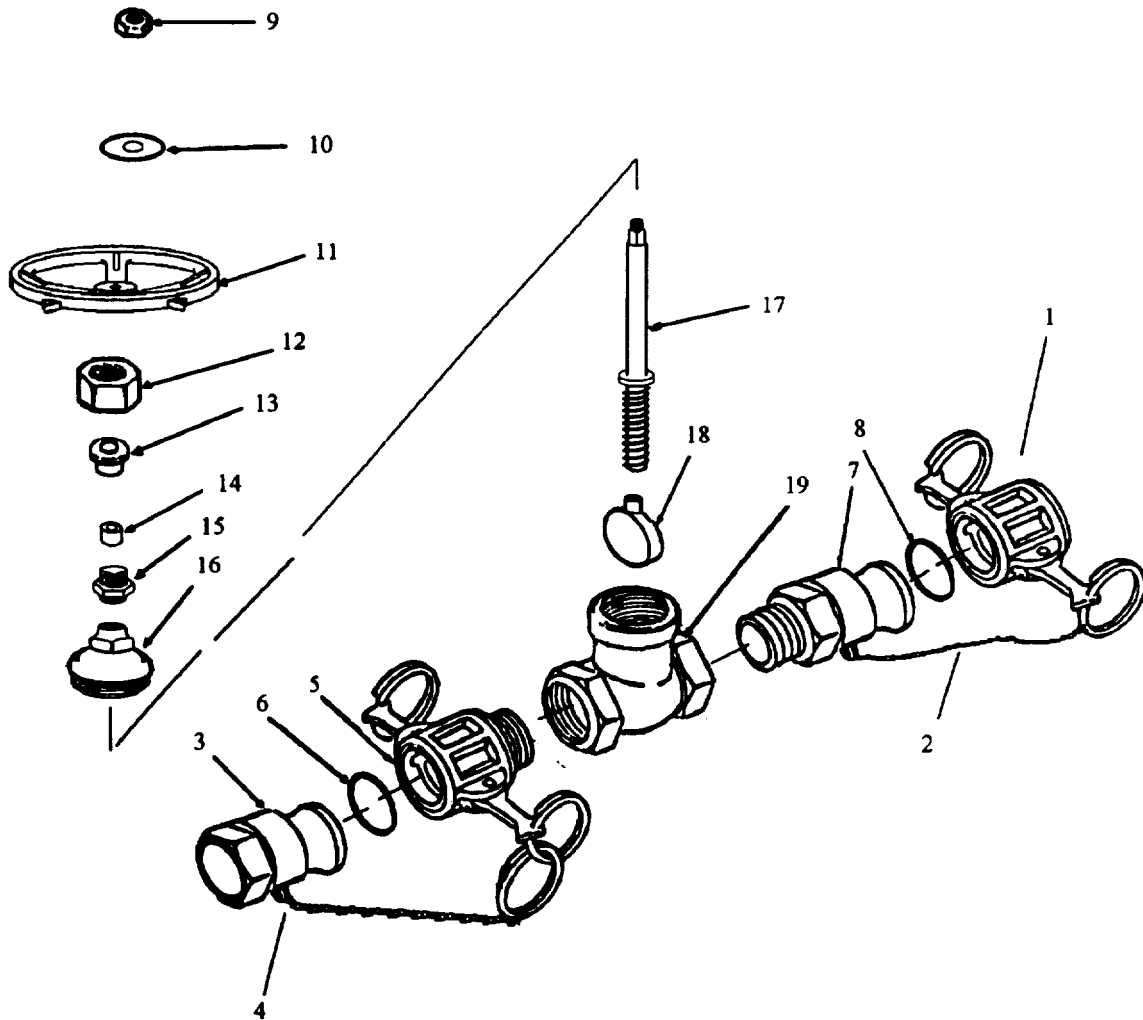

Gate Valve Assembly (2-inch) (Model ALP9440)

4.15 TEE ASSEMBLY MAINTENANCE.

NOTE

The following instructions apply to tee assemblies having two female couplings and one male coupling (FxFxM). Maintenance of other tee assemblies is similar.

This task consists of:

- | | |
|----------------|-----------------|
| a. Removal | e. Repair |
| b. Disassembly | f. Assembly |
| c. Cleaning | g. Installation |
| d. Inspection | |

INITIAL SET-UP:

Tools:

Tool Kit, General Mechanics, Automotive (Appendix B, Sec. III, item 1)

Materials/Parts Required:

Detergent, General Purpose (Item 1, Appendix D)

Rag, Wiping (Item 2, Appendix D)

NOTE

Determine additional materials required by using the following table.

Tee Assembly	Coupling Gasket	Flange Gasket
FxFxM	MS27030-9 (2)	13220E1069-1 (3)
FxMxM	MS27030-9 (1)	13220E1069-1 (3)
FxMxF	MS27030-9 (2)	13220E1069-1 (3)
MxMxF	MS27030-9 (1)	13220E1069-1 (3)

a. Removal. Disconnect tee assembly from water system (refer to para 2.10 to disconnect couplings).

b. Disassembly.

- (1) Remove eight nuts (7), lockwashers (6), flat washers (5 and 2), and bolts (1).
- (2) Separate male coupling (3) and gasket (4) from tee (8).
- (3) Remove eight nuts (24), lockwashers (23), flat washers (22 and 21), and bolts (20).
- (4) Separate male coupling (19) and gasket (18) from tee (8).
- (5) Remove eight nuts (9), lockwashers (10), flat washers (11 and 15), and bolts (16).
- (6) Separate female coupling (14) and gasket (12) from tee (8).
- (7) Remove gasket (17) from female coupling (14).

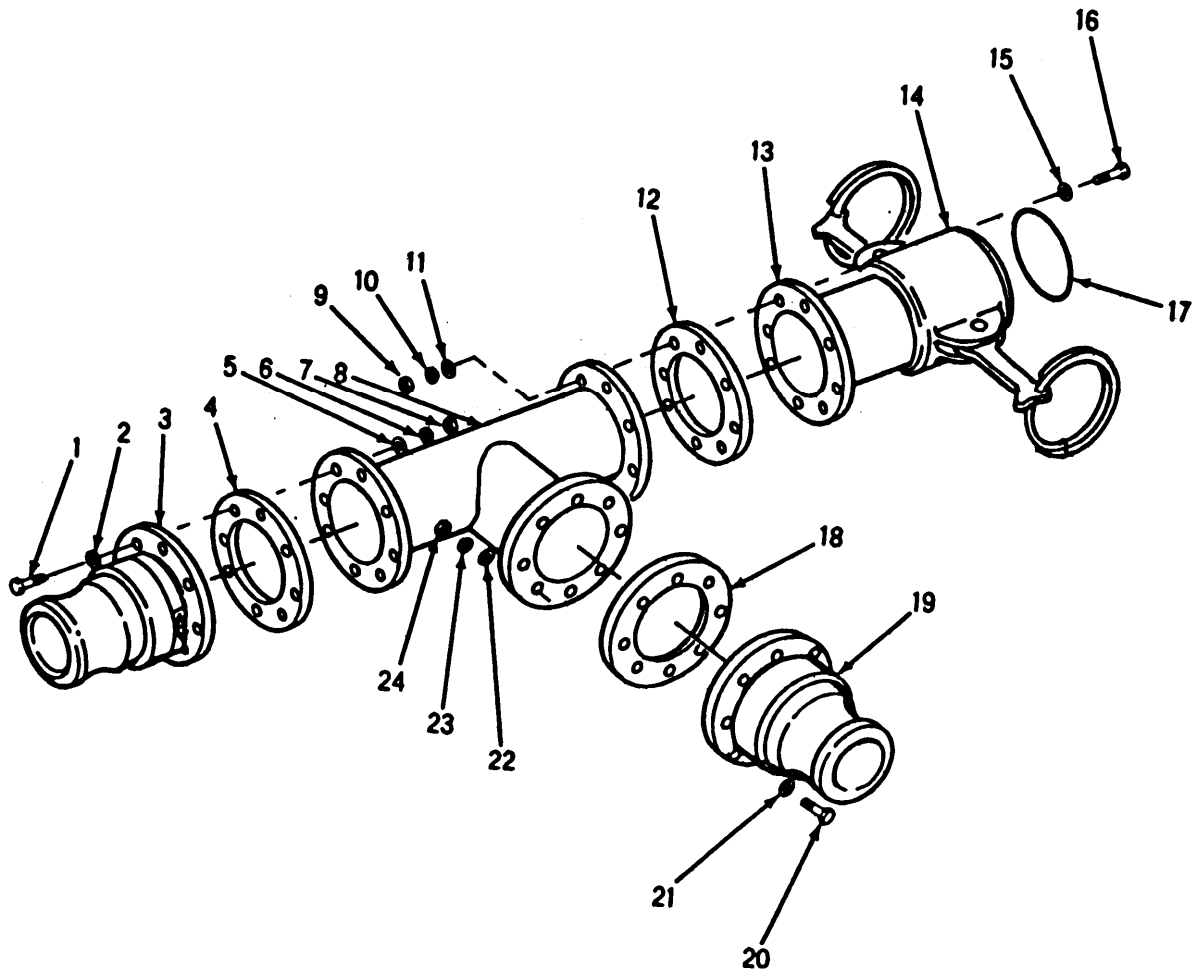

Tee Assembly

4.15 TEE ASSEMBLY MAINTENANCE - continued.

c. Cleaning.

- (1) Wash all components with clean water and detergent.
- (2) Rinse components in clean water and dry with wiping rag.

d. Inspection.

- (1) Inspect male couplings (3 and 19) for cracks.
- (2) Inspect female coupling (14) for cracks and damaged lock arms.
- (3) Inspect tee (8) for cracks and corrosion.

e. Repair. Replace defective components. Do not reuse flange gaskets or coupling gasket.

f. Assembly.

NOTE

Ensure gasket is fully seated in groove of coupling.

- (1) Install gasket (17) in female coupling (14).
 - (2) Position gasket (12) and female coupling (14) on tee (8).
 - (3) Install eight bolts (16), flat washers (15 and 11), lockwashers (10) and nuts (9).
 - (4) Position male coupling (19) and gasket (18) on tee (8).
 - (5) Install eight bolts (20), flat washers (21 and 22), lockwashers (23) and nuts (24).
 - (6) Position male coupling (3) and gasket (4) on tee (8).
 - (7) Install eight bolts (1), flat washers (2 and 5), lockwashers (6) and nuts (7).
- g. Installation. Connect tee assembly to water system (refer to para. 2.10 to connect couplings).

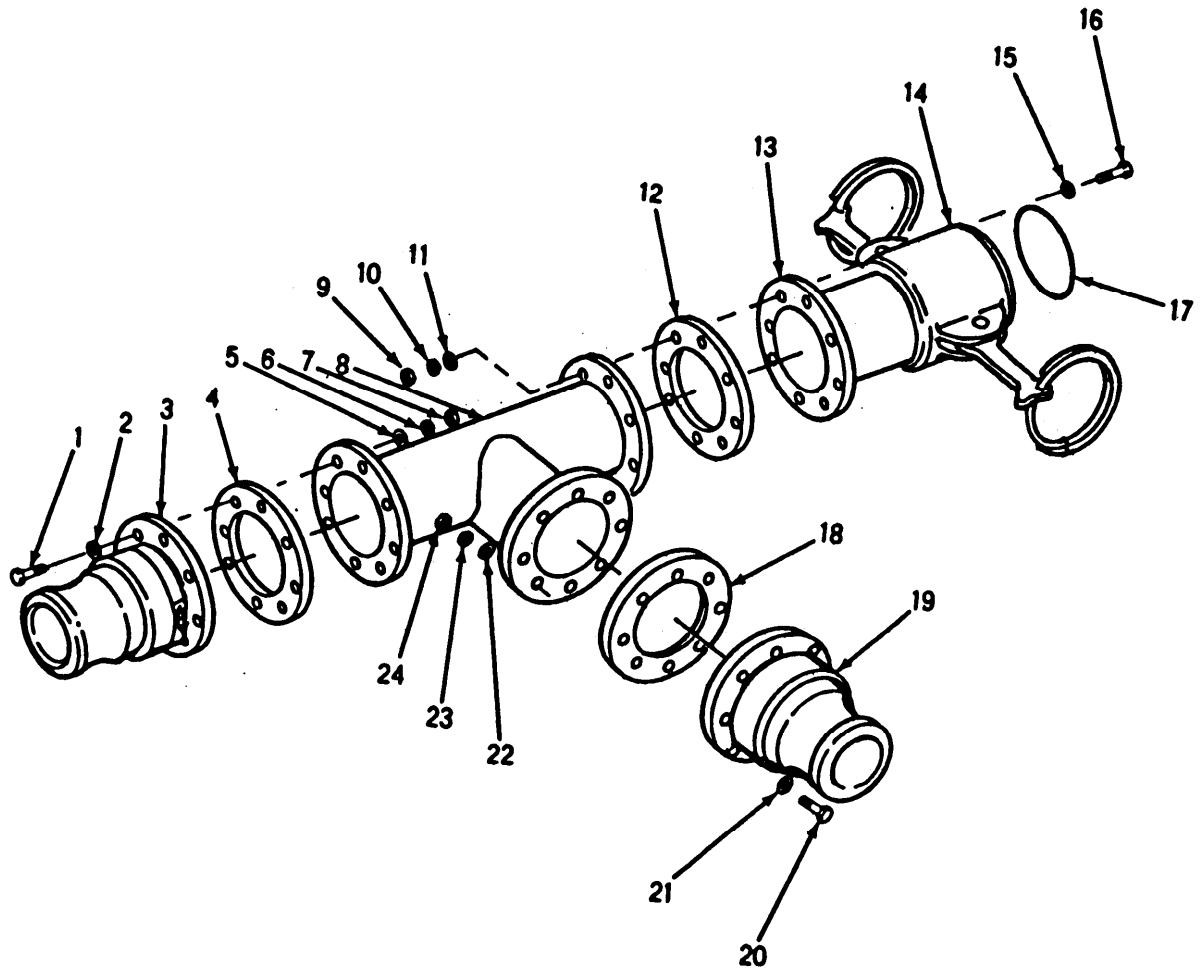

Tee Assembly

4.16 DISTRIBUTION NOZZLE (1-inch) ASSEMBLY MAINTENANCE.

This task consists of:

a. Removal

b. Installation

a. Removal. Disconnect distribution nozzle from water system (refer to para 2.10 to disconnect couplings).

b. Installation. Connect distribution nozzle to water system (refer to para. 2.10 to connect couplings).

4.17 WATER PRESSURE REGULATOR ASSEMBLY MAINTNEANCE.

This task consists of:	a. Removal b. Installation	c. Adjustment
------------------------	-------------------------------	---------------

INITIAL SET-UP:

Tools:

Tool Kit, General Mechanics, Automotive (Appendix B, Sec. III, item 1)
Vice (Appendix B, Sec. III, Item 2)

Equipment Condition:

Water system operating.

- a. Removal. Disconnect water pressure regulator from water system (refer to para 2.10 to disconnect couplings).
- b. Installation. Connect gate valve to water system (refer to para. 2.10 to connect couplings).
- c. Adjustment. If water pressure at distribution nozzle is not at desired pressure, proceed as follows:
 - (1) Loosen locknut (2).
 - (2) Squeeze distribution nozzle control lever and allow water to flow.
 - (3) Turn adjusting screw (1) counterclockwise to reduce water pressure or clockwise to increase water pressure.
 - (4) Tighten locknut (2).
 - (5) Release distribution nozzle control lever.

4.17 WATER PRESSURE REGULATOR ASSEMBLY MAINTNEANCE - continued.

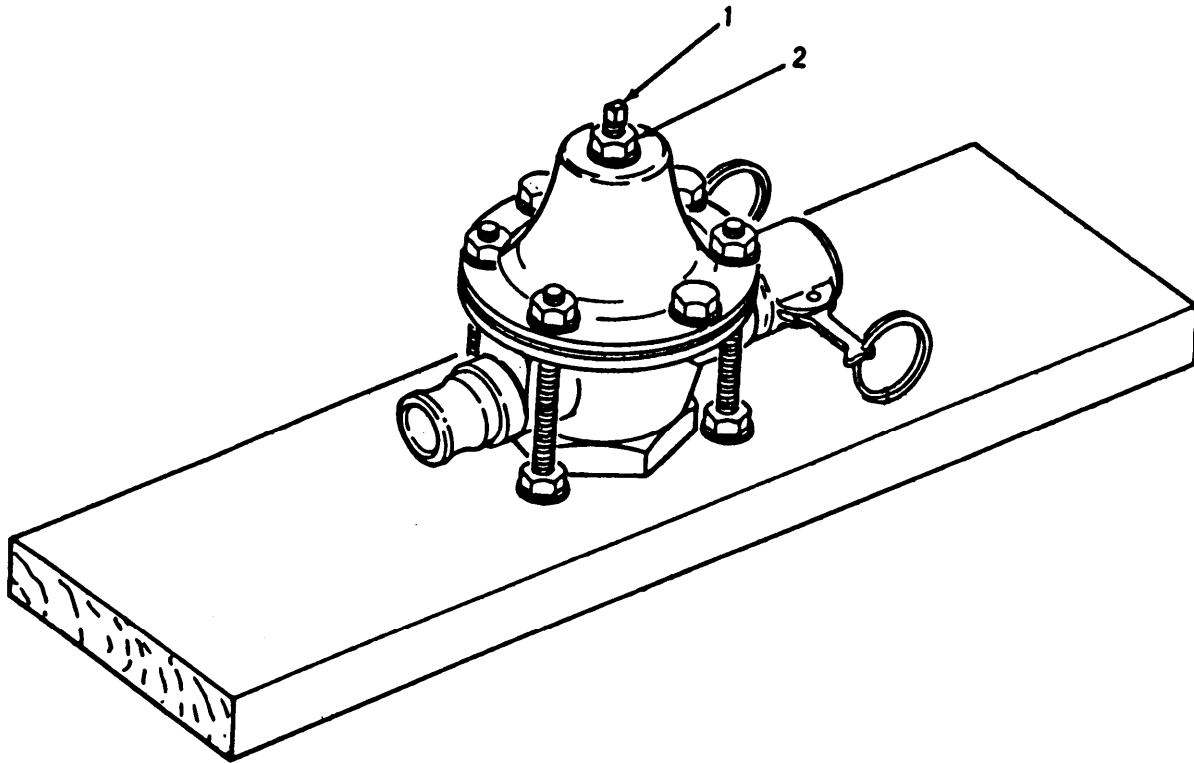

Water Pressure Regulator Assembly

4.18 NOZZLE STAND ASSEMBLY MAINTENANCE.

This task consists of:

- | | |
|----------------|-----------------|
| a. Removal | e. Repair |
| b. Disassembly | f. Assembly |
| c. Cleaning | g. Installation |
| d. Inspection | |

INITIAL SET-UP:

Tools:

Tool Kit, General Mechanics, Automotive (Appendix B, Sec. III, item 1)

Materials/Parts Required:

Detergent, General Purpose (Item 1, Appendix D)
 Rag, Wiping (Item 2, Appendix D)
 Cotter Pin (2) - MS24665-134

- a. Removal. Remove nozzle stand from water system.
- b. Disassembly.
 - (1) Unbend and remove S-hooks (4, 6, and 9) and disconnect chains (5,8, and 10).
 - (2) Remove cotter pin (2) and straight pin (1) from leg (3). Disconnect leg.
 - (3) Remove cotter pin (12) and straight pin (13) from leg (11). Disconnect leg.
- c. Cleaning.
 - (1) Wash all components with clean water and detergent.
 - (2) Rinse components in clean water and dry with wiping rag.
- d. Inspection.
 - (1) Inspect legs (3, 7, and 11) for cracks, broken clevis ends and missing nozzle hangers.
 - (2) Inspect chains (5, 8, and 10) for broken links.
- e. Repair. Replace defective components.
- f. Assembly.
 - (1) Align clevis fitting on leg (11) with pivot fitting on leg (7).
 - (2) Install straight pin (13). Install cotter pin (12) in straight pin.
 - (3) Align clevis fitting on leg (3) with pivot fitting on leg (7).
 - (4) Install straight pin (1). Install cotter pin (2) in straight pin.
 - (5) Connect chains (5,8, and 10) to legs (3, 7, and 11) with S-hooks (4, 6, and 9).
- g. Installation. Position nozzle stand in water system.

4.18 NOZZLE STAND ASSEMBLY MAINTENANCE - continued.

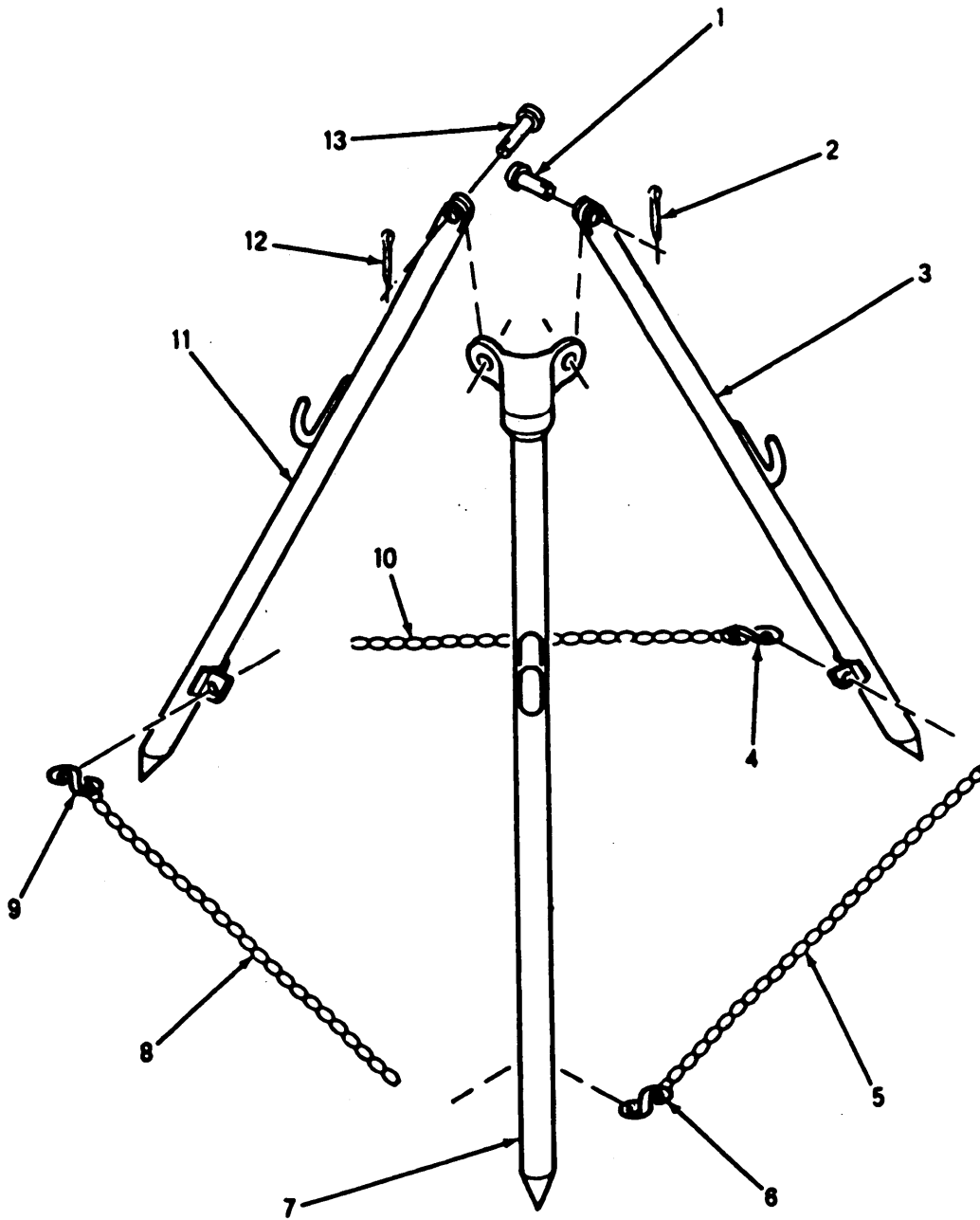

Nozzle Stand Assembly

4.19 HOSE NOZZLE KIT MAINTENANCE

The hose nozzle kit consists of the components listed below. Refer to the following paragraphs for applicable maintenance procedures.

Procedure	Para
Discharge Hose Assembly Maintenance	4.13
2-inch Gate Valve Assembly Maintenance	4.14
Tee Assembly Maintenance	4.15
Nozzle Stand Assembly Maintenance	4.18
Distribution Nozzle Assembly (1-1/2 inch)	4.20

4.20 DISTRIBUTION NOZZLE (1-1/2 INCH) ASSEMBLY MAINTNEANCE.

This task consists of:	a. Removal	b Installation
------------------------	------------	----------------

a. **Removal.** Disconnect distribution nozzle from water system (refer to para.2.10 to disconnect couplings).

b. **Installation.** Connect distribution nozzle to water system (refer to para.2.10 to connect couplings).

4.21 HOSE CONNECTION KIT (2-INCH) MAINTENANCE.

The hose connection kit (2-inch) consists of the components listed below. Refer to the following paragraphs for applicable maintenance procedures.

Procedure	Para
Discharge Hose Maintenance	4.13
2-inch Gate Valve Assembly Maintenance	4.14
Tee Assembly Maintenance	4.15
Nozzle Stand Assembly Maintenance	4.18

4.22 HYPOCHLORINATION UNIT MAINTENANCE.

Refer to TM 5-4610-233-13&P For Hypochlorination Unit maintenance instructions.

4.23 350 GPM PUMP CONNECTION KIT MAINTENANCE.

The 350 GPM Pump Connection Kit consists of the components listed below. Refer to the following paragraphs for applicable maintenance procedures.

Procedure	Para
Discharge and Suction Hose Maintenance	4.13
Tee Assembly Maintenance	4.15
4-inch Gate Valve Assembly Maintenance	4.24

4.24 GATE VALVE ASSEMBLY (4-INCH) MAINTENANCE.

This task consists of:

- | | |
|----------------|-----------------|
| a. Removal | e. Repair |
| b. Disassembly | f. Assembly |
| c. Cleaning | g. Installation |
| d. Inspection | |
-

INITIAL SET-UP:

Tools:

- Tool Kit, General Mechanics, Automotive (Appendix B, Sec. III, item 1)
- Mallet (Appendix B, Sec. III, Item 2)
- Vice (Appendix B, Sec. III, Item 2)

Materials/Parts Required:

- Detergent, General Purpose (Item 1, Appendix D)
 - Rag, Wiping (Item 2, Appendix D)
 - Gasket, Flange (2) - X-3702C
 - Ring, Packing (3) - 235RF-05082P
 - Gasket, Body - 235RF-05092G
 - Gasket, Coupling - MS27030-9
-

NOTE

The following procedures describe a 4-inch gate valve with one male and one female coupling installed. Repair of other 4-inch gate valves is similar.

- a. Removal. Disconnect gate valve from water system (refer to para 2.10 to disconnect couplings).
- b. Disassembly.
 - (1) Remove eight nuts (23), lockwashers (21), washers (19), and bolts (18).
 - (2) Separate flanged coupling (17) and gasket (16) from valve body (15).
 - (3) Remove eight nuts (20), lockwashers (22), washers (24), and bolts (25).
 - (4) Separate flanged coupling (27) and gasket (28) from valve body (15).
 - (5) Remove gasket (26) from flanged coupling (27).
 - (6) Remove nut (1) and handwheel (2) from stem (10).
 - (7) Remove packing nut (3), gland spring (4), packing ring (5) and packing gland (6).
 - (8) Remove eight nuts (29), lockwashers (30), and bolts (7).
 - (9) Remove bonnet (8), gasket (9), and attached parts from valve body (15).

NOTE

If needed, tap bonnet (8) with mallet to loosen sealing surfaces.

- (10) Remove two screws (13) and separate discs (12 and 14) from disc riser (11).
- (11) Remove disc riser (11) from stem (10).
- (12) Unscrew stem (10) from bonnet (8) and remove stem.

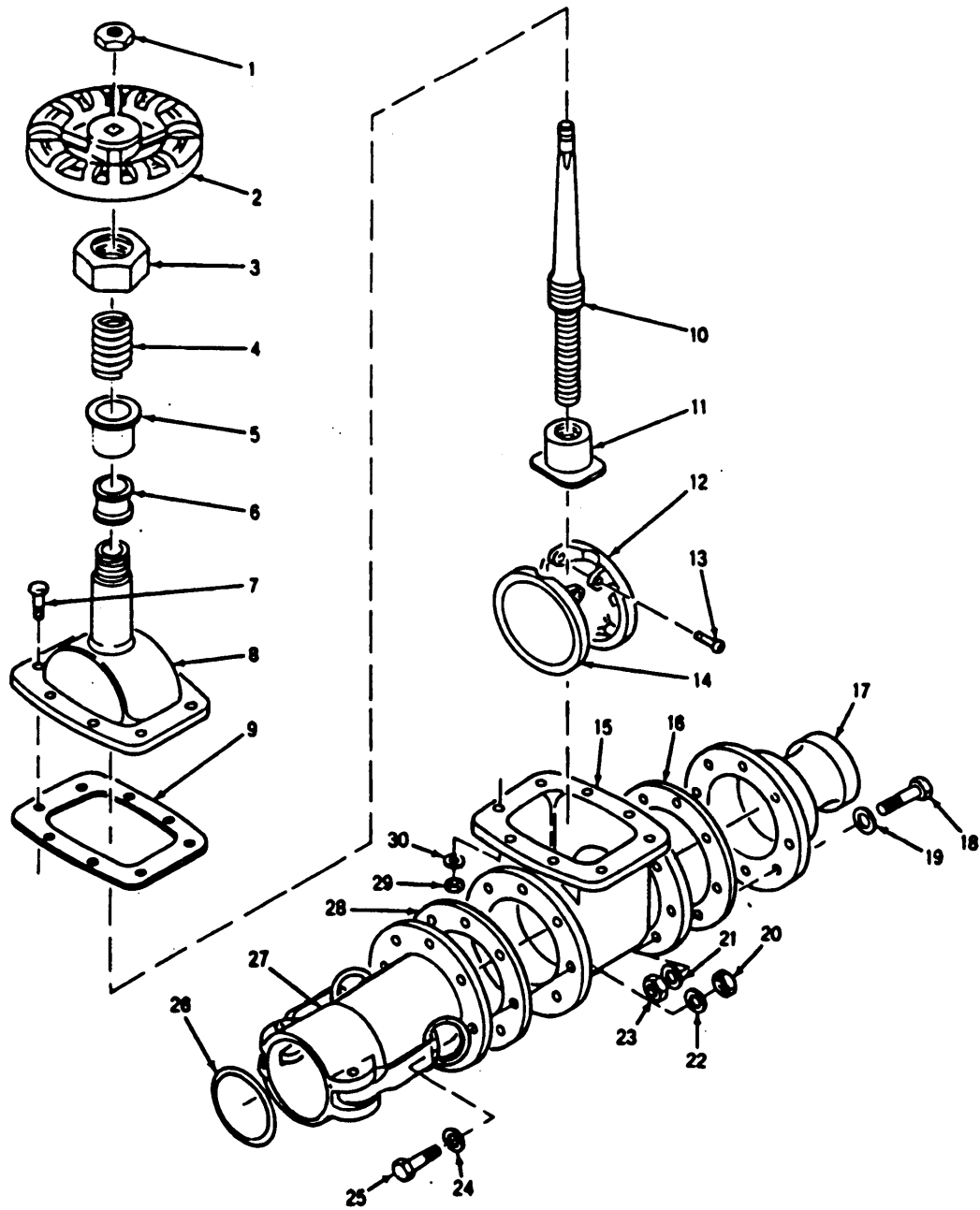

Gate Valve Assembly (4-inch)

4.24 GATE VALVE ASSEMBLY (4-INCH) MAINTNEANCE - continued.

c. Cleaning.

- (1) Clean all components with clean water and detergent.
- (2) Rinse components in clean water and dry with wiping rag.

d. Inspection.

- (1) Inspect bonnet (8), valve body (15) and flanged couplings (17and27) for cracks, scored mating surfaces, stripped threads and corrosion.
- (2) Inspect for bent stem (10). Inspect for galled or stripped threads.
- (3) Inspect sealing surfaces of discs (12 and 14) for deep scratches and cracks.

e. Repair. Replace damaged parts and all sealing components.

f. Assembly.

- (1) Screw stem (10) into bonnet (8).
- (2) Install disc riser (11) on stem (10).
- (3) Install discs (12 and 14) on riser (11) with two screws (13).
- (4) Turn stem (10) counterclockwise until discs (12 and 14) retract into bonnet (8).
- (5) Position gasket (9) on valve body (15). Guide bonnet (8) and attached parts onto valve body.
- (6) Install eight botts (7), lockwashers (30) and nuts (29).
- (7) Install gasket (26) in flanged coupling (27).
- (8) Position flanged coupling (27) and gasket (28) on valve body (15).
- (9) Install eight bolts (25), washers (24), lockwashers (22) and nuts (20).
- (10) Position flanged coupling (17) and gasket (16) on valve body (1 5).
- (11) Install eight bolts (18), washers (19), lockwashers (21) and nuts (23).

g. Installation. Connect gate valve to water system (refer to para. 2.10 to connect couplings).

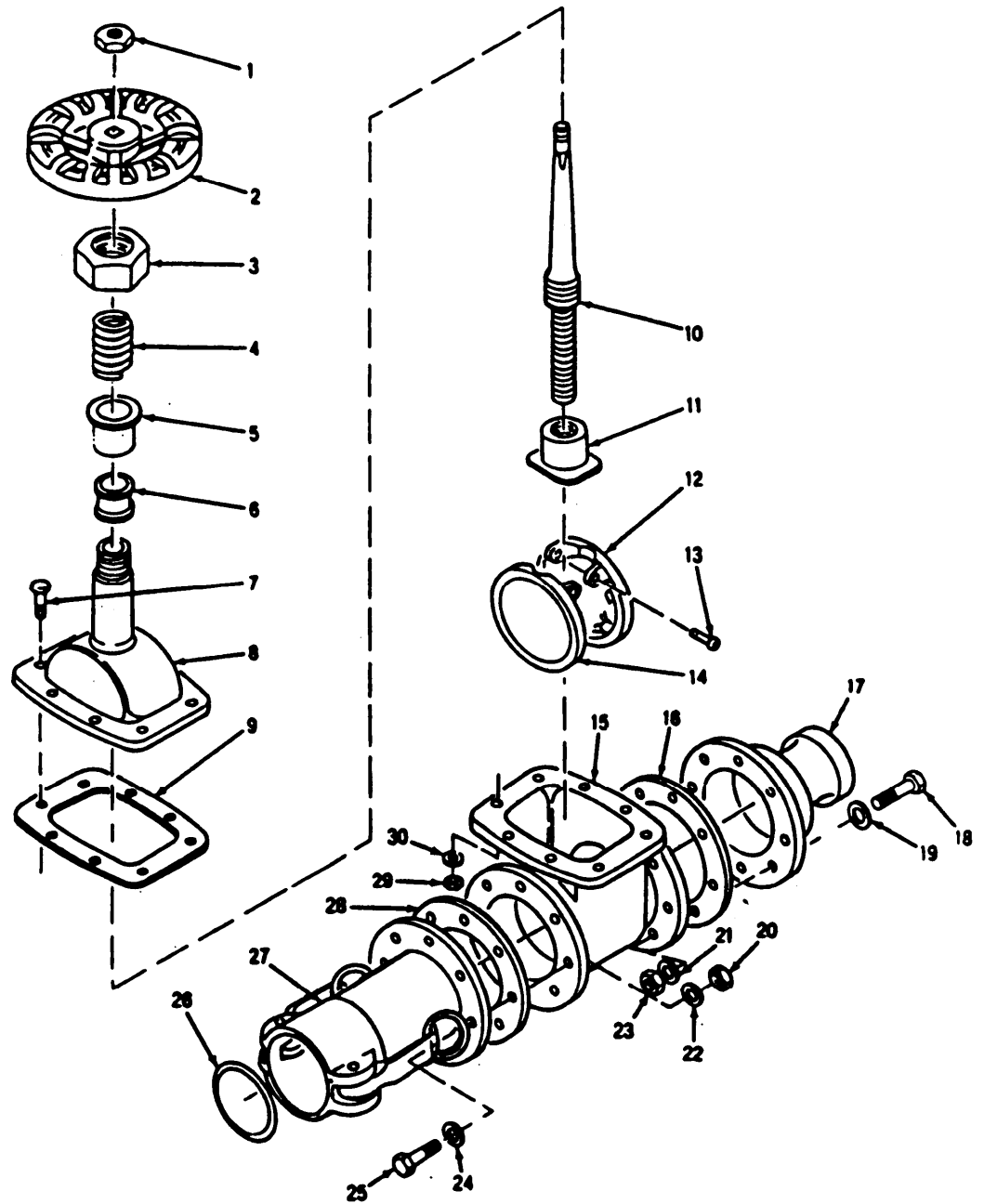

Gate Valve Assembly (4-inch)

4.25 WATER METER ASSEMBLY MAINTENANCE. (Model WSDS40K)

This task consists of:

- | | |
|----------------|-----------------|
| a. Removal | e. Repair |
| b. Disassembly | f. Assembly |
| c. Cleaning | g. Installation |
| d. Inspection | |
-

INITIAL SET-UP:

Tools:

Tool Kit, General Mechanics, Automotive (Appendix B, Sec. III, item 1)

Materials/Parts Required:

Detergent, General Purpose (Item 1, Appendix D)
Rag, Wiping (Item 2, Appendix D)
Gasket, Coupling - MS27030-9
Gasket, Full Face (2) - 13225E9177-3
Gasket -8341-304
Lock nuts (16)

- a. Removal. Disconnect water meter from water system (refer to para 2.10 to disconnect couplings).
- b. Disassembly.
 - (1) Disconnect ring (7) from coupling half (4). Remove dust plug (8).
 - (2) Remove eight lock nuts (9) and screws (5).
 - (3) Separate coupling half (4) and gasket (3) from main case (10).
 - (4) Remove gasket (6) from coupling half (4).
 - (5) Disconnect ring (13) from coupling half (15). Remove dust cap (12).
 - (6) Remove gasket (11) from dust cap (12).
 - (7) Remove eight lock nuts (17) and screws (14).
 - (8) Separate coupling half (15) and gasket(16) from main case (10).
 - (9) Remove 10 bolts (1).
 - (10) Lift cover assembly (2) from main case (10).
 - (11) Remove gasket (18) from main case (10).

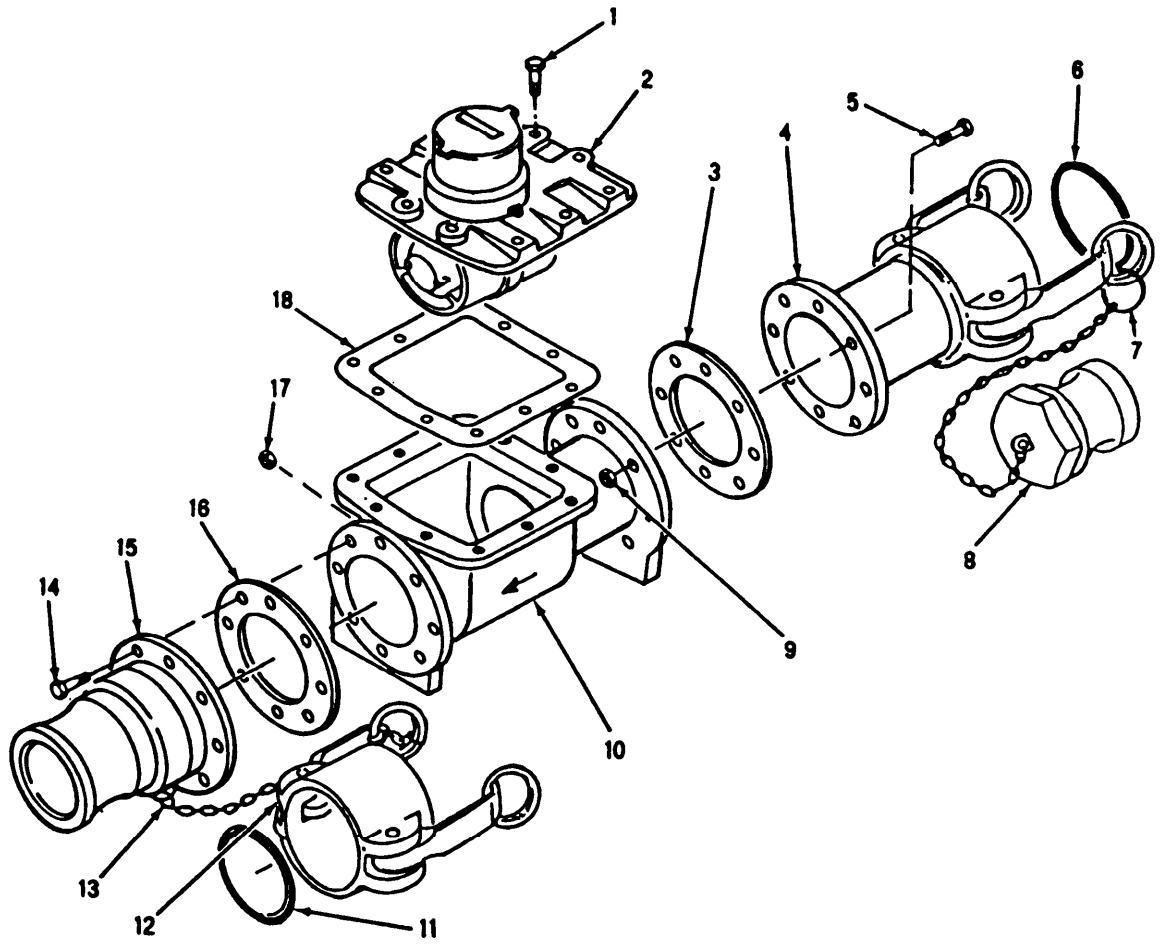

Water Meter Assembly (Model WSDS40K)

4.25 WATER METER ASSEMBLY MAINTENANCE - continued.

c. Cleaning.

- (1) Clean all components with clean water and detergent.
- (2) Rinse components in clean water and dry with wiping rag.

d. Inspection.

- (1) Inspect coupling halves (4 and 15), dust plug (8) and dust cap (12) for cracks.
- (2) Inspect main case (10) for cracks and corrosion.
- (3) Inspect cover assembly (2) for cracks, damage and corrosion.

e. Repair. Replace damaged parts, all sealing components and lock nuts.

f. Assembly.

- (1) Position gasket (18) on main case (10).
- (2) Lower cover assembly (2) onto main case (10).
- (3) Install 10 bolts (1).
- (4) Position gasket (16) and coupling half (15) on main case (10).
- (5) Install eight screws (14) and lock nuts (17).

NOTE

Ensure gasket is fully seated in groove of dust cap.

- (6) Install gasket (11) in dust cap (12).
- (7) Connect dust cap (12) to coupling half (15) with ring (13).
- (8) Position gasket (3) and coupling half (4) on main case (10).
- (9) Install eight screws (5) and lock nuts (9).
- (10) Connect dust plug (8) to coupling half (4) with ring (7).

NOTE

Ensure gasket is fully seated in groove of coupling half.

- (11) Install gasket (6) in coupling half (4).

g. Installation. Connect water meter to water system (refer to para. 2.10 to connect couplings).

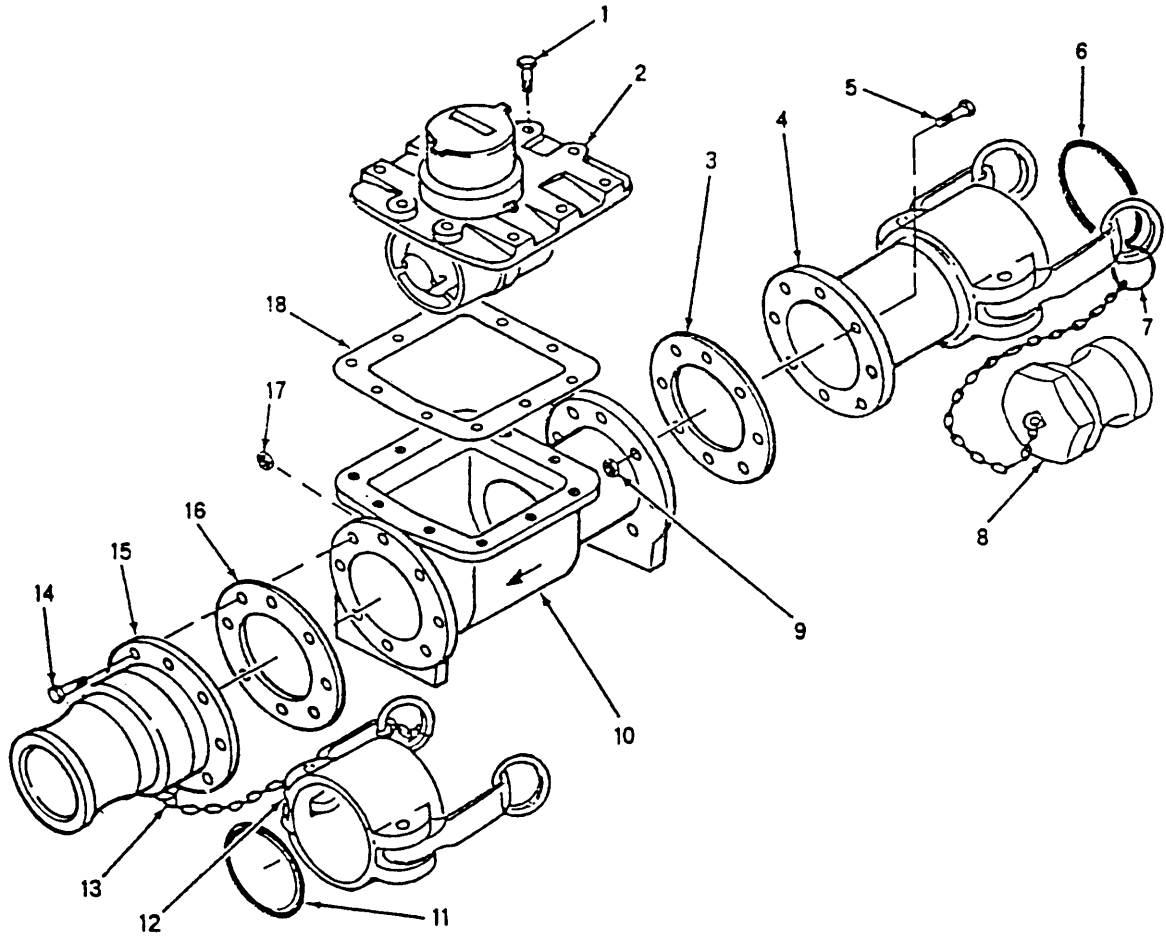

Water Meter Assembly (Model WSDS40K)

4.25.1 WATER METER ASSEMBLY MAINTENANCE (MODEL 40KWSDS).

- | | | |
|------------------------|----------------|-----------------|
| This task consists of: | a. Removal | e. Repair |
| | b. Disassembly | f. Assembly |
| | c. Cleaning | g. Installation |
| | d. Inspection | |
-

INITIAL SET-UP:

Tools:

Tool Kit, General Mechanics, Automotive (Appendix B, Sec. III, Item 1)

Materials/Parts Required:

Detergent, General Purpose (Item 1, Appendix D)

Rag, Wiping (Item 2, Appendix D)

Gasket, Coupling (2) - MS27030-9

Gasket, Full Face (2) - ASME-B16.21

Gasket -8341-304

Self Locking Nuts (16) - MS51922-54

a. Removal. Disconnect water meter from water system (refer to para 2.10 to disconnect couplings).

b. Disassembly

- (1) Disconnect ring (1) from female coupling (12) and remove plug (2).

NOTE

The two screws (5) that attach support bracket (7) to the flange of the water meter are longer than the other six screws (10) used on the flange.

- (2) Remove two self locking nuts (3), flat washers (4), screws (5) and flat washers (6).
- (3) Remove support bracket (7) from water meter body (27).
- (4) Remove six self locking nuts (8), flat washers (9), screws (10) and flat washers (11).
- (5) Remove female coupling (12) and gasket (13).
- (6) Remove gasket (14) from water meter body (27).
- (7) Disconnect ring (15) from male coupling (22) and remove cap (16).
- (8) Remove gasket (17) from cap (16).
- (9) Remove eight self locking nuts (18), flat washers (19), screws (20) and flat washers (21).
- (10) Remove male coupling (22) and gasket (23).
- (11) Remove 8 bolts (24).
- (12) Separate meter unit (25) and gasket (26) from meter main case (27).

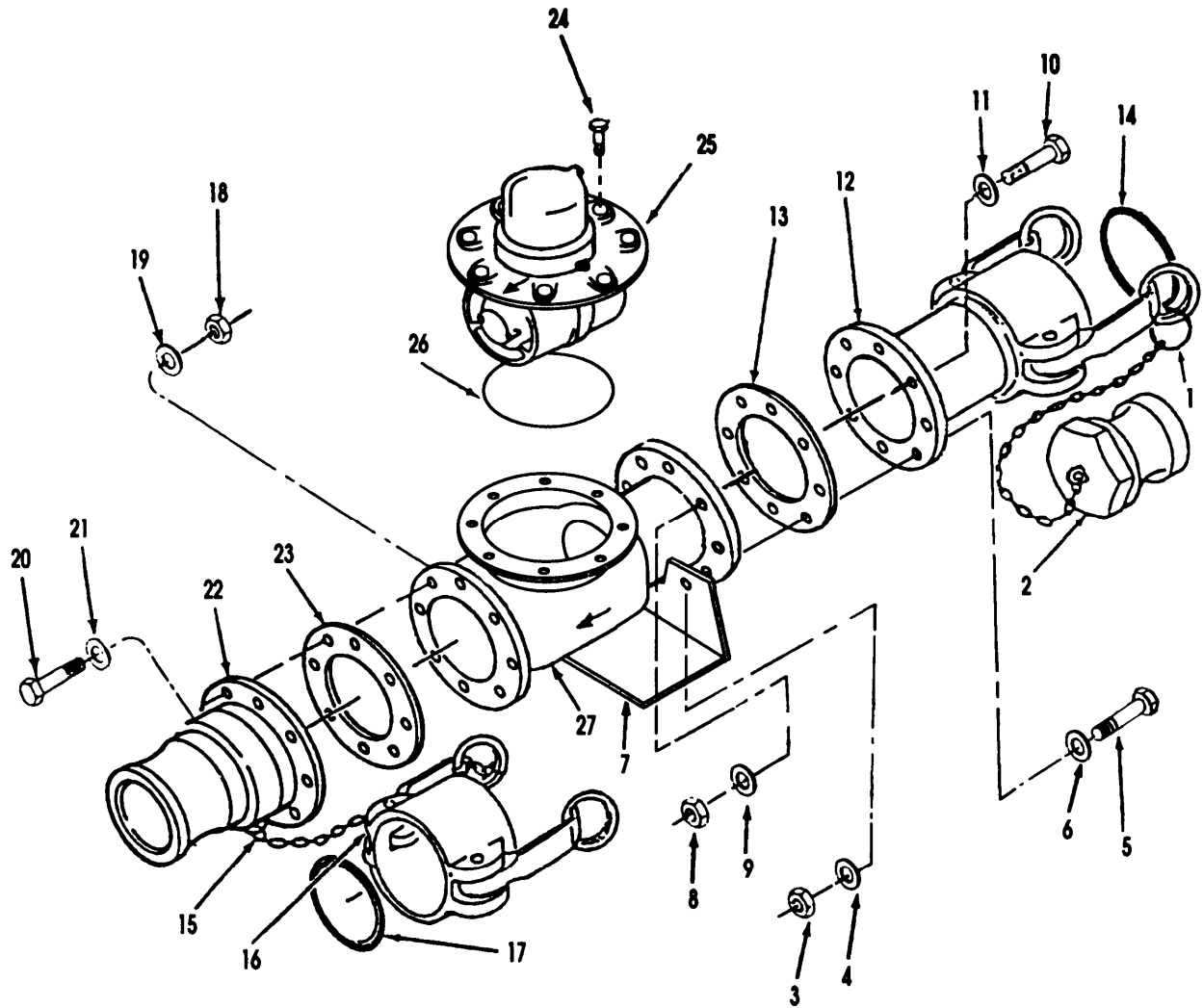

Water Meter Assembly (Model 40KWSDS)

c. Cleaning.

- (1) Wash all components with clean water and detergent.
- (2) Rinse components in clean water and dry with wiping rag.

d. Inspection.

- (1) Inspect female coupling (12) and male coupling (22) for cracks and corrosion.
- (2) Inspect water meter main case (27) for cracks, damage and corrosion.
- (3) Inspect meter unit (25) for cracks, damage and corrosion.

e. Repair. Replace damaged or defective parts. Replace gaskets (14 and 17), flange gaskets (13 and 23), meter gasket (26) and self locking nuts (3, 8 and 18).

f. Assembly.

- (1) Position gasket (26) on meter main case (27).
- (2) Lower meter unit (25) onto gasket (26) and meter main case (27). Make sure arrow on top of the meter unit is pointing in the same direction as the arrow on the main case.
- (3) Install 8 bolts (24).
- (4) Position gasket (23) and male coupling (22) on outlet flange of water meter main case (27).
- (5) Install eight flat washers (21) , screws (20), flat washers(19) and self locking nuts (18).

NOTE

Ensure gasket is fully seated in groove of cap.

- (6) Install gasket (17) in cap (16).
- (7) Connect cap (16) to male coupling (22) with ring (15).
- (8) Position gasket (13) and female coupling (12) on inlet flange of water meter main case (27).

NOTE

The two screws (5) that attach support bracket (7) to the flange of the water meter are longer than the other six screws (10) used on the flange.

- (9) Install six flat washers (11), 3 1/4-inch long screws (10), flat washers (9) and self locking nuts (8).
- (10) Position support bracket (7) on water meter body (27).
- (11) Install two flat washers (6), 3 3/4-inch long screws (5), flat washers (4) and self locking nuts (3).

NOTE

Ensure gasket is fully seated in groove of female coupling.

- (12) Install gasket (14) in female coupling (12).
- (13) Connect plug (2) to female coupling (12) with ring (1).

g. Installation. Connect water meter to water system (refer to para 2.10 to connect couplings).

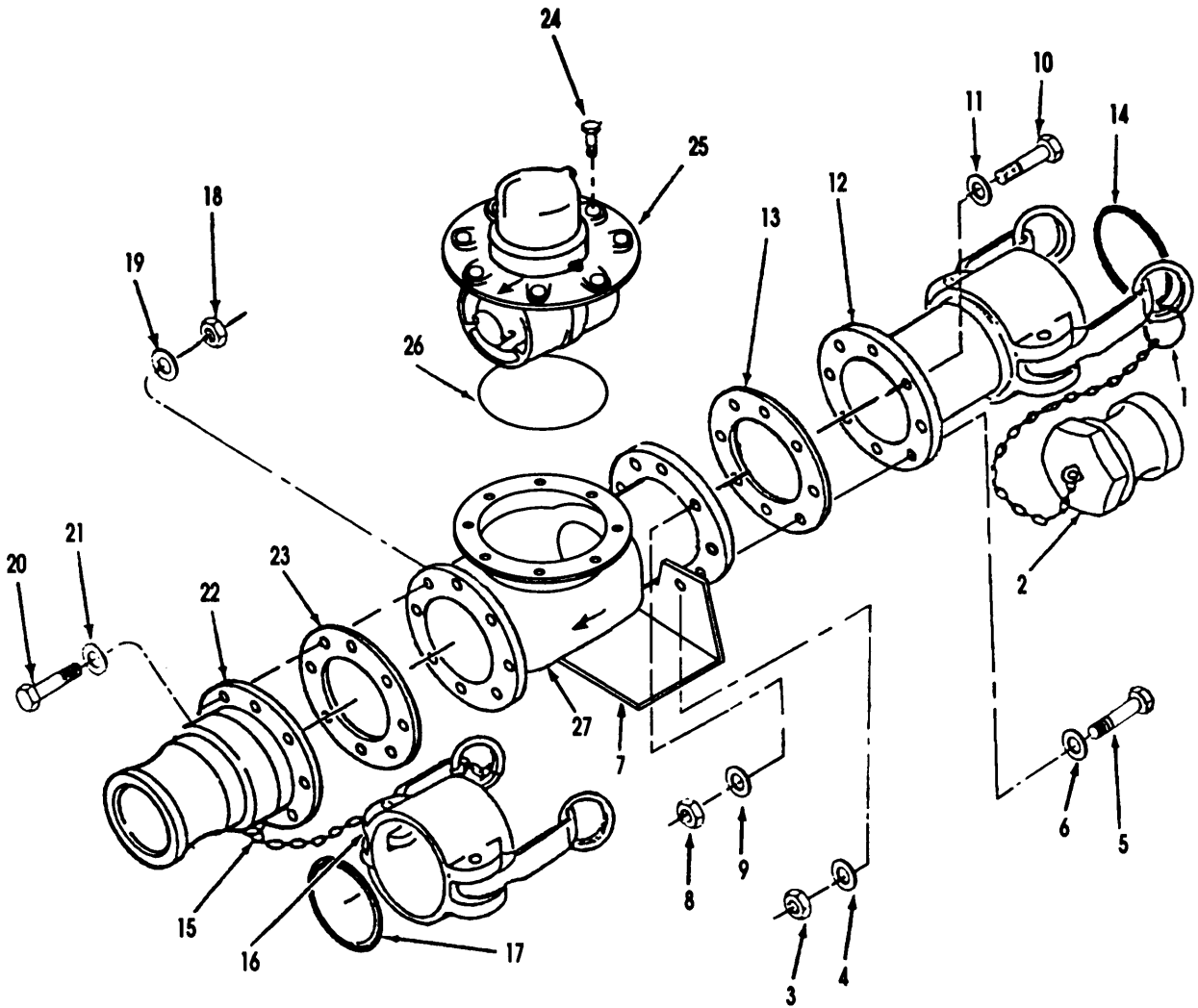

Water Meter Assembly (40KWSDS)

4.26 350 GPM PUMPING ASSEMBLY MAINTENANCE.

Refer to TM 5-4320-226-14 for 350 GPM Pumping Assembly maintenance instructions.

4.27 125 GPM CONNECTION KIT MAINTENANCE.

The 125 GPM connection kit consists of the components listed below. Refer to the following paragraphs for applicable maintenance procedures.

Procedure	Para
Discharge and Suction Hose Maintenance	4.13
2-inch Gate Valve Assembly Maintenance	4.14
Check Valve Assembly Maintenance	4.28

4.28 CHECK VALVE ASSEMBLY MAINTENANCE (MODELS WSDS40K & 40KWSDS)

This task consists of:	a. Removal	e. Repair
	b. Disassembly	f. Assembly
	c. Cleaning	g. Installation
	d. Inspection	

INITIAL SET-UP:

Tools:

Tool Kit, General Mechanics, Automotive (Appendix B, Sec. III, item 1)
 Vice (Appendix B, Sec. III, Item 2)
 Pipe Wrench (from Accessory Kit)

Materials/Parts Required:

Detergent, General Purpose (Item 1, Appendix D)
 Rag, Wiping (Item 2, Appendix D)
 Tape, Anti-seize (Item 3, Appendix D)
 Gasket, Coupling - MS27030-6

- a. Removal. Disconnect check valve from water system (refer to para 2.10 to disconnect couplings).
- b. Disassembly.
 - (1) Using pipe wrench, unscrew coupling half (3) from body (7).
 - (2) Remove gasket (4) from coupling half (3).
 - (3) Using pipe wrench, unscrew coupling half (8) from body (7).
 - (4) Using pipe wrench, remove cap (1).
 - (5) Remove plug (5).
 - (6) Pull pin (6) from body (7).
 - (7) Remove lever (10) and attached parts from body (7).
 - (8) Remove retaining ring (9) and separate disc (2) from lever (10).
- c. Cleaning.
 - (1) Clean all components with clean water and detergent.
 - (2) Rinse components in clean water and dry with wiping rag.

4.28 CHECK VALVE ASSEMBLY MAINTENANCE (MODELS WSDS40K & 40KWSDS) (continued)

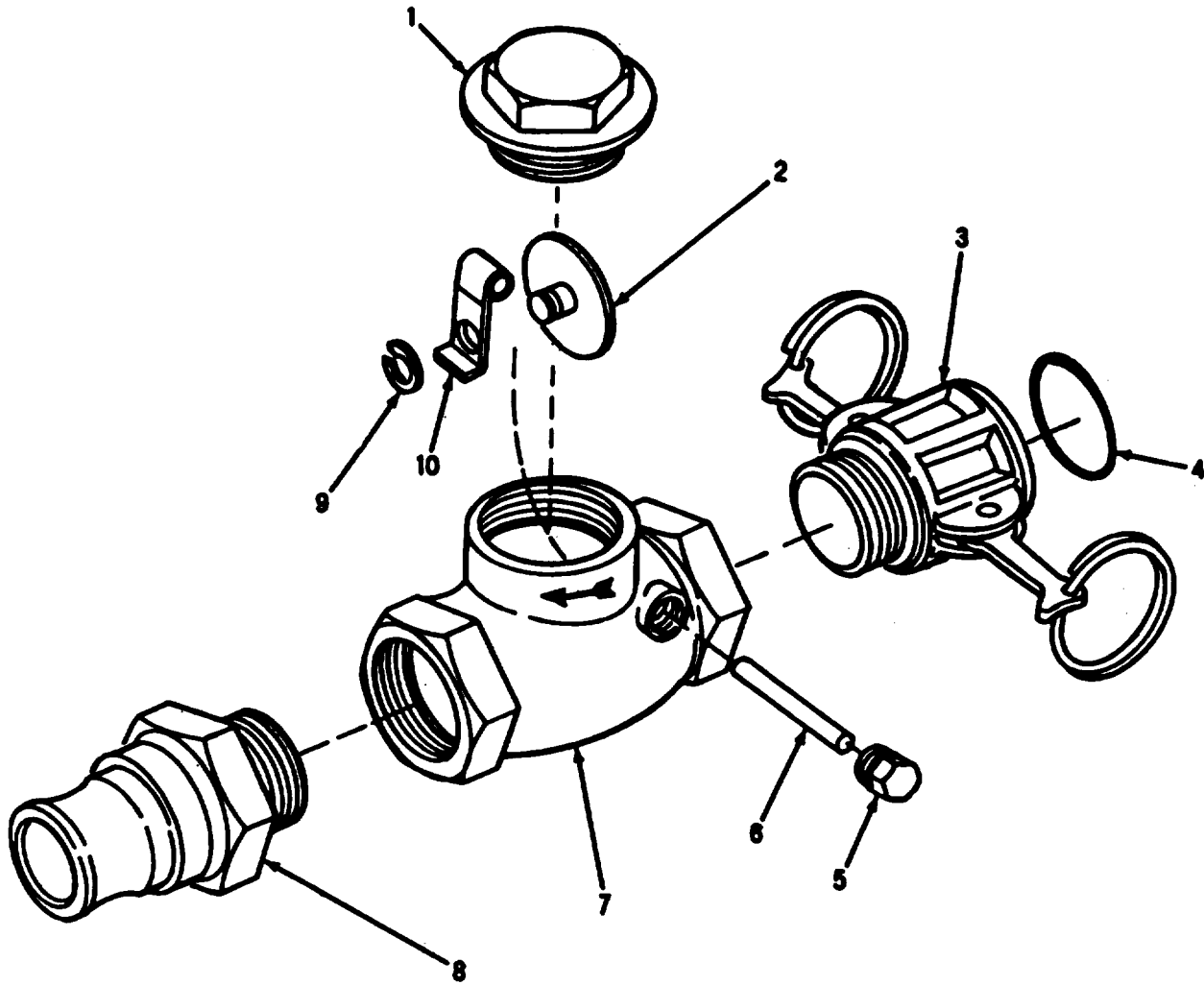

Check Valve Assembly (Models WSDS40K & 40KWSDS)

d. Inspection.

- (1) Inspect body (7) and cap (1) for cracks, corrosion and stripped or damaged threads.
- (2) Inspect coupling halves (8 and 3) for cracks and stripped or damaged threads.
- (3) Inspect disc (2) for cracks and distortion.

e. Repair. Replace damaged parts.f. Assembly.

- (1) Position disc (2) on lever (10) and install retaining ring (9).

NOTE

Disc sealing surface must face inlet side of valve.

- (2) Position disc (2) and attached parts in body (7).
- (3) Push pin (6) through body (7) and into lever (10).
- (4) Apply anti-seize tape to threads of plug (5). Using pipe wrench, install plug.
- (5) Apply anti-seize tape to threads of cap (2). Using pipe wrench, install cap.

NOTE

Ensure coupling half (8) is installed on outlet side of valve.

- (6) Apply anti-seize tape to threads of coupling half (8). Using pipe wrench, screw coupling half into body (7).

NOTE

Ensure gasket is fully seated in groove of coupling half.

- (7) Install gasket (4) in coupling half (3).
- (8) Apply anti-seize tape to threads of coupling half (3). Using pipe wrench, screw coupling half into body (7).

g. Installation. Connect check valve to water system (refer to para. 2.10 to connect couplings).

4.28 CHECK VALVE ASSEMBLY MAINTENANCE (MODELS WSDS40K & 40KWSDS) (continued)

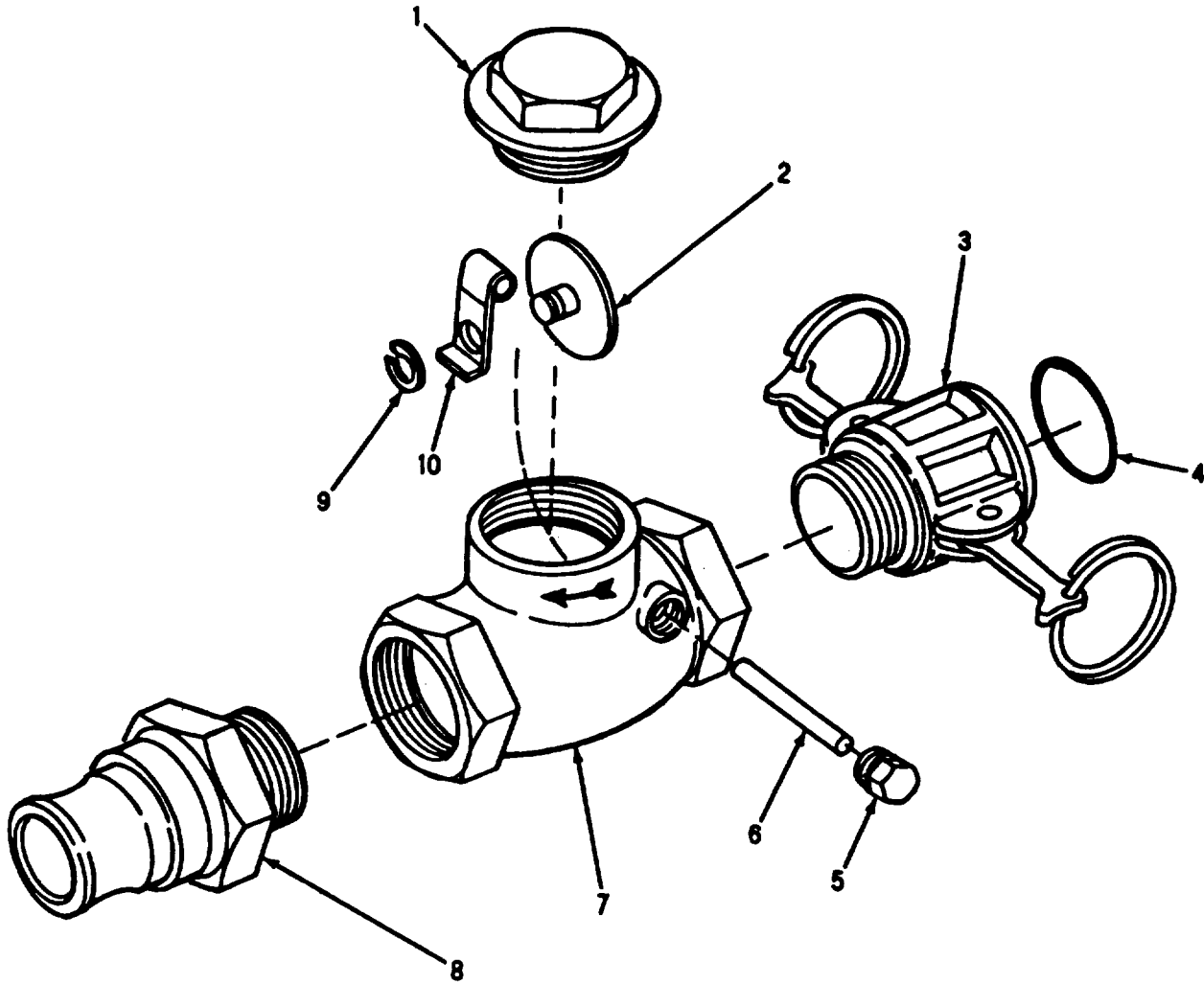

Check Valve Assembly (Models WSDS40K & 40KWSDS)

4.28.1 CHECK VALVE ASSEMBLY MAINTENANCE (MODEL ALP9440)

This task consists of	a. Removal	e. Repair
	b. Disassembly	f. Assembly
	c. Cleaning	g. Installation
	d. Inspection	

INITIAL SET-UP:**Tools:**

Tool Kit, General Mechanics, Automotive (Appendix B, Sec. III, Item 1)
 Vice (Appendix B, Sec. III, Item 2)
 Pipe Wrench (from Accessory Kit)

Materials/Parts Required:

Detergent, General Purpose (Appendix D, Item 1)
 Rag, Wiping (Appendix D, Item 2)
 Tape, Anti-seize (Appendix D, Item 3)
 Gasket, Coupling, MS27030-6

- a. Removal. Disconnect check valve from water system (refer to para. 2.10 to disconnect couplings).
- b. Disassembly.
 - (1) Clamp check valve in vice.
 - (2) Remove cap (1) from male coupler (5).
 - (3) Remove chain (2) from cap (1) and male coupler (5).
 - (4) Remove plug (3) from female coupler (6).
 - (5) Remove chain (4) from plug (3) and female coupler (6).
 - (6) Using pipe wrench, unscrew male coupler (5) from check valve body (13).
 - (7) Using pipe wrench, unscrew female coupler (6) from check valve body (13).
 - (8) Remove gasket (7) from female coupler (6).
 - (9) Remove gasket (8) from cap (1).
 - (10) Using pipe wrench, remove valve body cap (9) from valve body (13).
 - (11) Unscrew threaded plug (11) from valve body (13).
 - (12) Pull pin (10) from valve body (13).
 - (13) Remove disc assembly (12) from valve body (13).
- c. Cleaning.
 - (1) Clean all components with clean water and detergent.
 - (2) Rinse components in clean water and dry with wiping rag.
- d. Inspection.
 - (1) Inspect check valve body (13) and cap (1) for cracks, corrosion and stripped or damaged threads.
 - (2) Inspect coupling halves (5 and 6) for cracks and stripped or damaged threads.
 - (3) Inspect disc (12) for cracks and distortion.
- e. Repair. Replace damaged parts.

4.28.1 CHECK VALVE ASSEMBLY MAINTENANCE (MODEL ALP9440) (continued)

f. Assembly.

NOTE

Disc sealing surface must face inlet side of valve.

- (1) Position disc assembly (12) in valve body (13).
- (2) Push pin (10) through valve body (13) and into lever of disc assembly (12).
- (3) Apply anti-seize tape to threads of threaded plug (11). Screw threaded plug (11) into valve body (13).
- (4) Apply anti-seize tape to threads of valve body cap (9). Using pipe wrench, install valve body cap (9) in valve body (13).

NOTE

Ensure male coupling half (5) is installed on outlet side of valve. See water flow arrow on valve body (13)

- (5) Apply anti-seize tape to threads of male and female coupling halves (5 and 6).
- (6) Using pipe wrench, screw male coupling half (5) into outlet side of valve body (13).
- (7) Using pipe wrench, screw female coupling half (6) into inlet side of valve body (13).

NOTE

Ensure gasket is fully seated in groove of each coupling half

- (8) Install gasket (7) in female coupling half (6).
- (9) Install gasket (8) in cap (1).

g. Installation. Connect check valve to water system (refer to para. 2.10 to connect couplings).

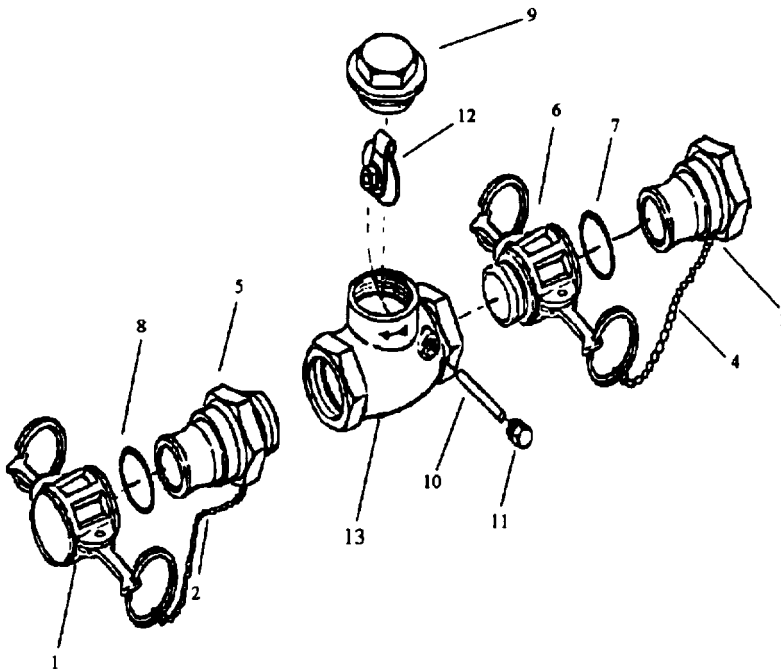

Check Valve Assembly (Model ALP9440)

4.29 125 GPM PUMPING ASSEMBLY MAINTENANCE.

Refer to TM 5-4320-304-14 or TM 10-4320-309-14 for 125 GPM Pumping Assembly maintenance instructions.

4.30 DUAL TANK CONNECTION KIT MAINTENANCE.

The dual tank connection kit consists of the components listed below. Refer to the following paragraphs for applicable maintenance procedures.

Procedure	Para
Discharge and Suction Hose Maintenance	4.13
Tee and Gate Valve Assembly	4.31

4.31 TEE AND GATE VALVE ASSEMBLY MAINTENANCE.

This task consists of:	a. Removal b. Repair	c. Installation
------------------------	-------------------------	-----------------

INITIAL SET-UP:

Tools:

- Tool Kit, General Mechanics, Automotive (Appendix B, Sec. III, item 1)
- Mallet (Appendix B, Sec. III, Item 2)
- Vice (Appendix B, Sec. III, Item 2)

Materials/Parts Required:

- Detergent, General Purpose (Item 1, Appendix D)
- Rag, Wiping (Item 2, Appendix D)
- Gasket, Flange (2) - X-3702C
- Ring, Packing (3) - 235RF-05082P
- Gasket, Body - 235RF-05092G
- Gasket, Coupling - MS27030-9

NOTE

Determine additional materials required by using the following table.

Tee Assembly	Coupling Gasket	Flange Gasket
FxFxM	MS27030-9 (2)	13220E1069-1 (3)
FxMxM	MS27030-9 (1)	13220E1069-1 (3)
FxMxF	MS27030-9 (2)	13220E1069-1 (3)
MxMxF	MS27030-9 (1)	13220E1069-1 (3)

NOTE

The following procedures describe a typical tee and gate valve assembly. Different combinations of male and female coupling halves maybe installed on the tee. Repair of other tee and gate valve assemblies is similar.

- a. Removal. Disconnect tee and gate valve from water system (refer to para. 2.10 to disconnect couplings).
- b. Repair. Refer to paragraph 4.15 for repair of tee assembly. Refer to para. 4.24 for repair of 4-inch gate valve.
- c. Installation. Connect tee and gate valve assembly to water system (refer to para. 2.10 to connect couplings).

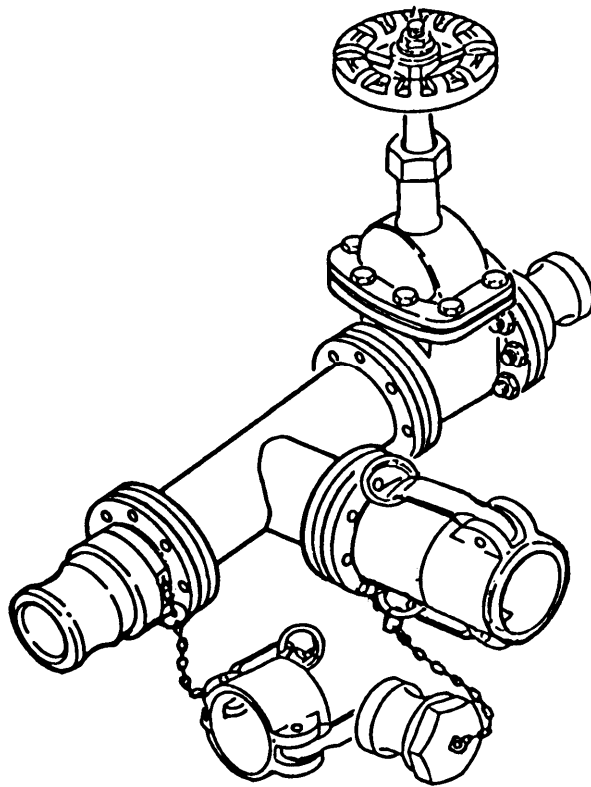

Tee and Gate, Valve Assembly

TM 10-4610-234-13

4.32 20,000 GALLON COLLAPSIBLE FABRIC TANK MAINTENANCE.

Refer to TM 5-5430-226-12 for 20,000 Gallon Collapsible Fabric Tank maintenance instructions.

4.33 ACCESSORY KIT MAINTENANCE.

The accessory kit contains components used to adapt the water system to different operating requirements. Unit maintenance of the accessory kit is limited to replacement of components to maintain complete inventory of parts in the kit.

4.34 WATER TANK CHEST MAINTENANCE.

This task consists of:	a. Replacement b. Disassembly	c. Repair d. Assembly
------------------------	----------------------------------	--------------------------

INITIAL SET-UP:

Tools:

Tool Kit, General Mechanics, Automotive (Appendix B, Sec. III, item 1)

Materials/Parts Required:

Detergent, General Purpose (Item 1, Appendix D)

Rag, Wiping (Item 2, Appendix D)

Gasket (roll) -22036-9 (for top cover)

Gasket (roll) -22036-8 (for end panel)

Gasket (roll) -22002-17 (for side panel)

-
- a. Replacement. If water tank chest is damaged beyond repair, replace water tank chest.
 - b. Dissassembly.
 - (1) Unfasten eight latches (5) located on side panels (4 and 10).
 - (2) Lift top cover (1) from tank chest.
 - (3) Move four handles (8) on end panel (9) to OPEN position. Remove end panel from water tank chest.
 - (4) Repeat step (3) for other end panel (3).
 - (5) Unlock four locking pins (6) and lift side panel (4) from skid (7).
 - (6) Repeat step (5) for other side panel (10).
 - (7) Remove divider pan (2) from skid (7).

4.34 WATER TANK CHEST MAINTENANCE - continued.

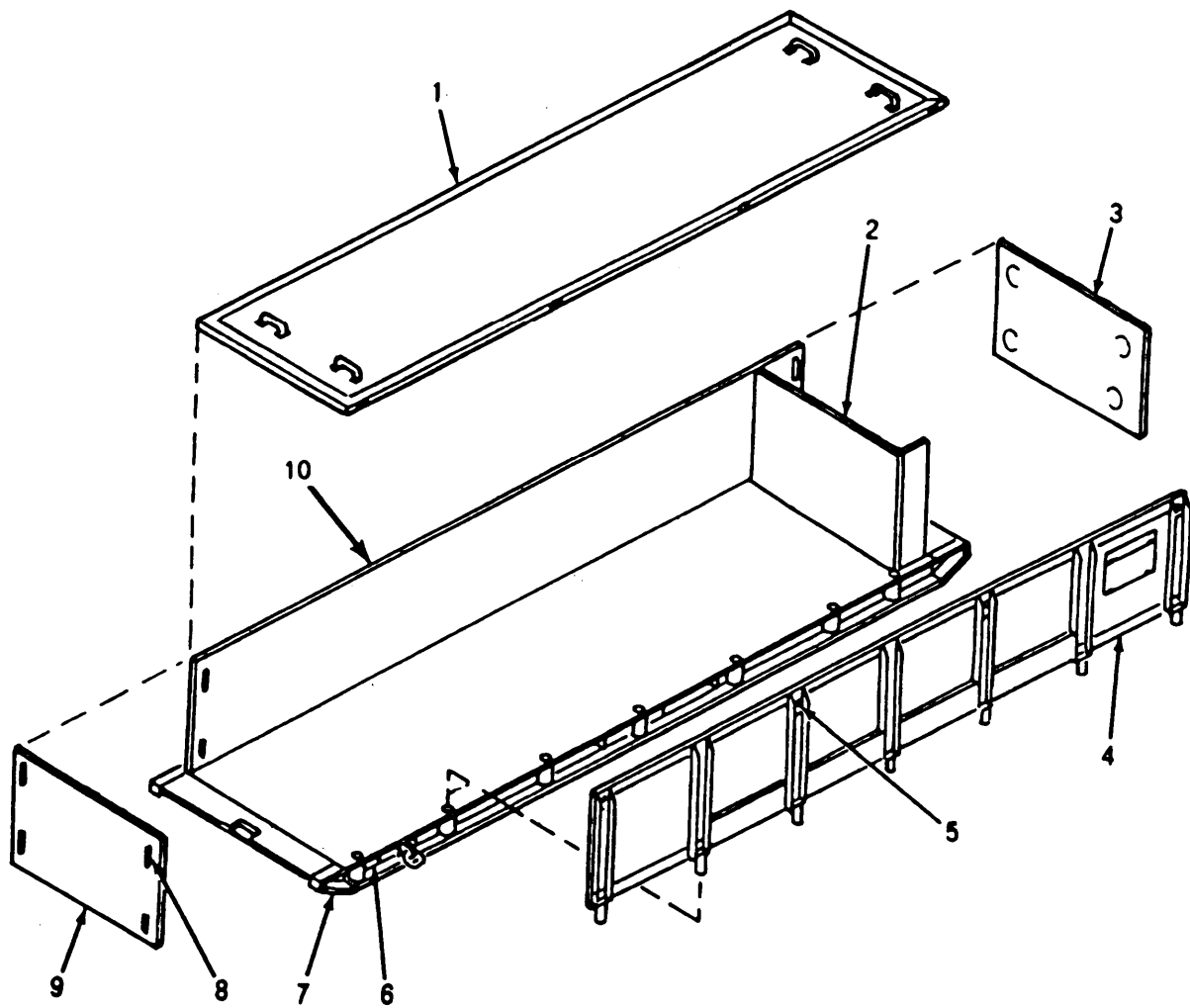

Water Tank Chest

c. Repair

(1) Top Cover Repair.

- (a) Peel damaged gasket material (1) from top cover (2).
- (b) Clean top cover (2) gasket mounting surface with detergent and clean water.
- (c) Wipe dry with wiping rag.

NOTE

Gasket material is supplied in rolls 34 feet long.

- (d) Cut two lengths of gasket material (1) 13-1/2 feet long.
- (e) Cut two lengths of gasket material (1) 3-1/2 feet long.
- (f) Peel backing from gasket material (1) and press in place on top cover (2).
- (g) Replace top cover if damaged beyond repair.

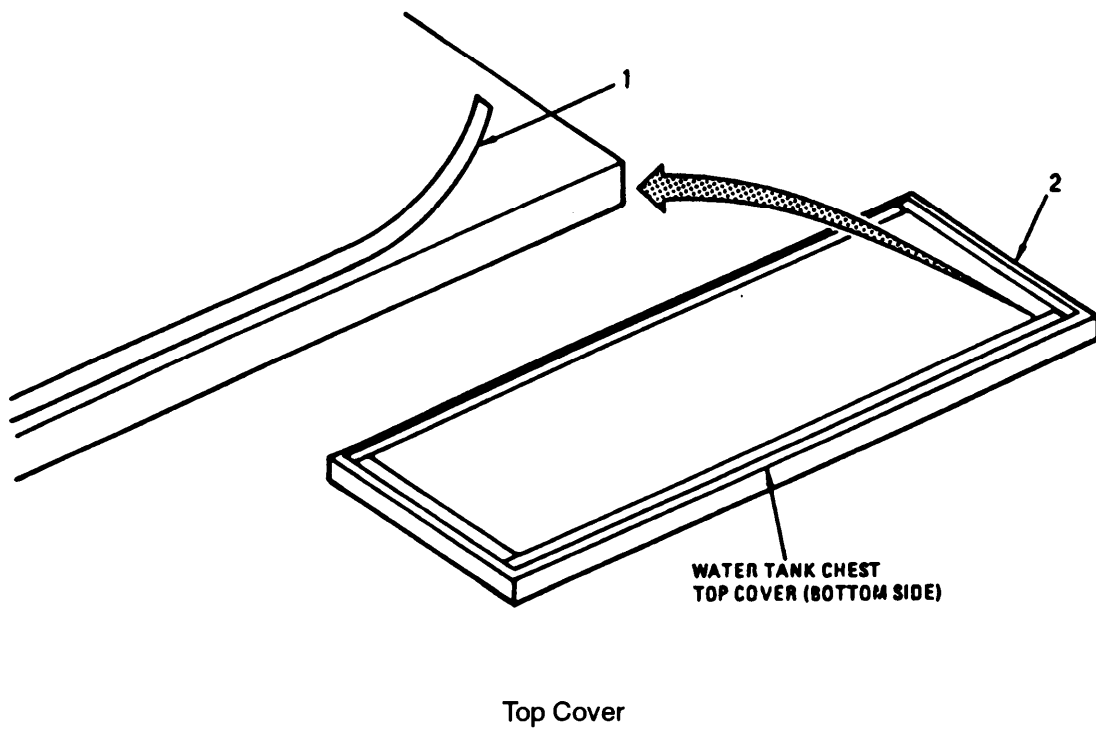

4.34 WATER TANK CHEST MAINTENANCE - continued.

(2) End Panel Repair.

(a) Gasket replacement.

- 1 Peel damaged gasket material (6) from end panel (5).
- 2 Clean end panel (5) gasket mounting surface with detergent and clean water.
- 3 Wipe dry with wiping rag.

NOTE

Gasket material is supplied in rolls. Cut gasket to length as required.

- 4 Peel backing from gasket material (1) and press in place on end panel (5).

(b) Handle replacement.

- 1 Remove pin (7) from handle (3).
- 2 Remove handle (3) and flat washer (4).
- 3 Position washer (4) and handle (3) on end panel (5).
- 4 Insert pin (7) into opening in handle (3).

(c) Replace end panel if damaged beyond repair.

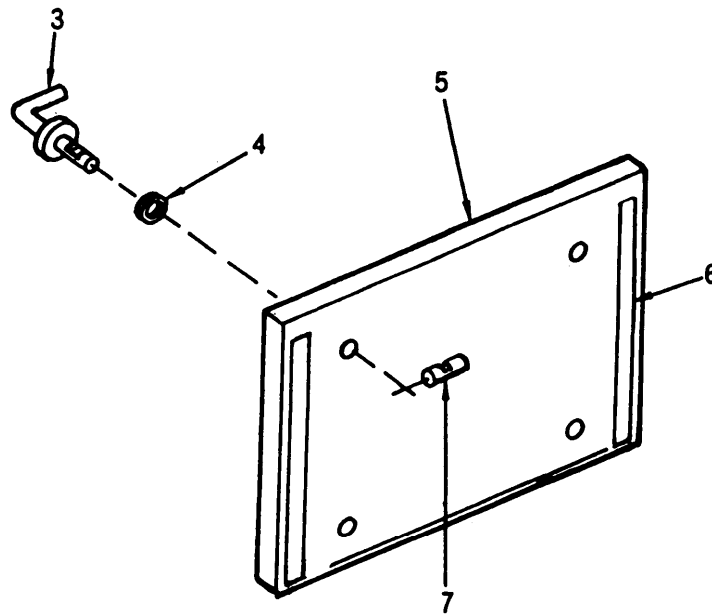

End Panel

(3) Side Panel Repair.

- (a) Peel damaged gasket material (8) from side panel (9).
- (b) Clean side panel (9) gasket mounting surface with detergent and clean water.
- (c) Wipe dry with wiping rag.

NOTE

Gasket material is supplied in rolls. Cut gasket to length as required.

- (d) Peel backing from gasket material (8) and press in place on side panel (9).
- (e) Replace side panel if damaged beyond repair.

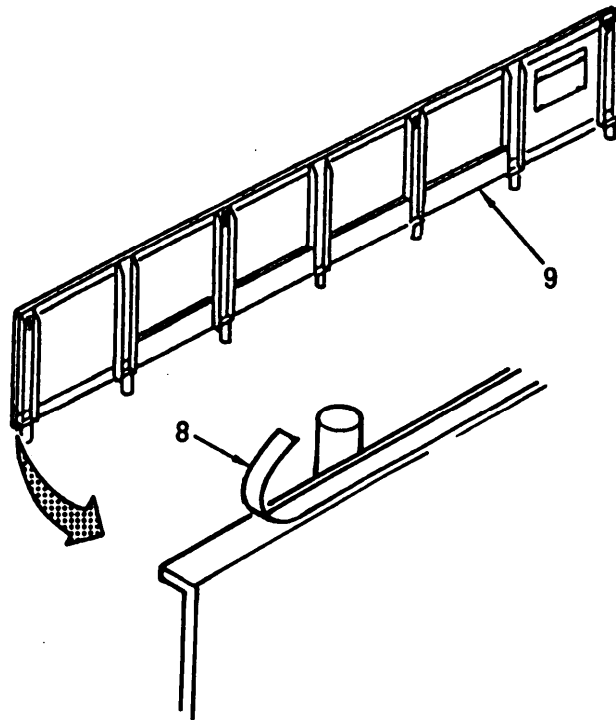

Side Panel

4.34 WATER TANK CHEST MAINTENANCE - continued.

(4) Skid Repair.

(a) Hoisting ring replacement.

- 1 Unscrew hoisting ring (11) from skid (10).
- 2 Screw replacement hoisting ring (11) into skid (10).

(b) Locking pin replacement.

- 1 Remove three nuts (19), lockwashers (18), washers (17 and 14) and screws (13) from skid (10).
- 2 Separate outer latch bracket (16) and inner latch bracket (15) from skid (10).
- 3 Remove locking pin (12) from inner latch bracket (15).
- 4 Position replacement locking pin (12) in inner latch bracket (15).
- 5 Position inner latch bracket (15) and outer latch bracket on skid (10).
- 6 Install three screws (13), washers (14 and 17), lockwashers (18) and nuts (19).

(c) Replace skid if damaged beyond repair.

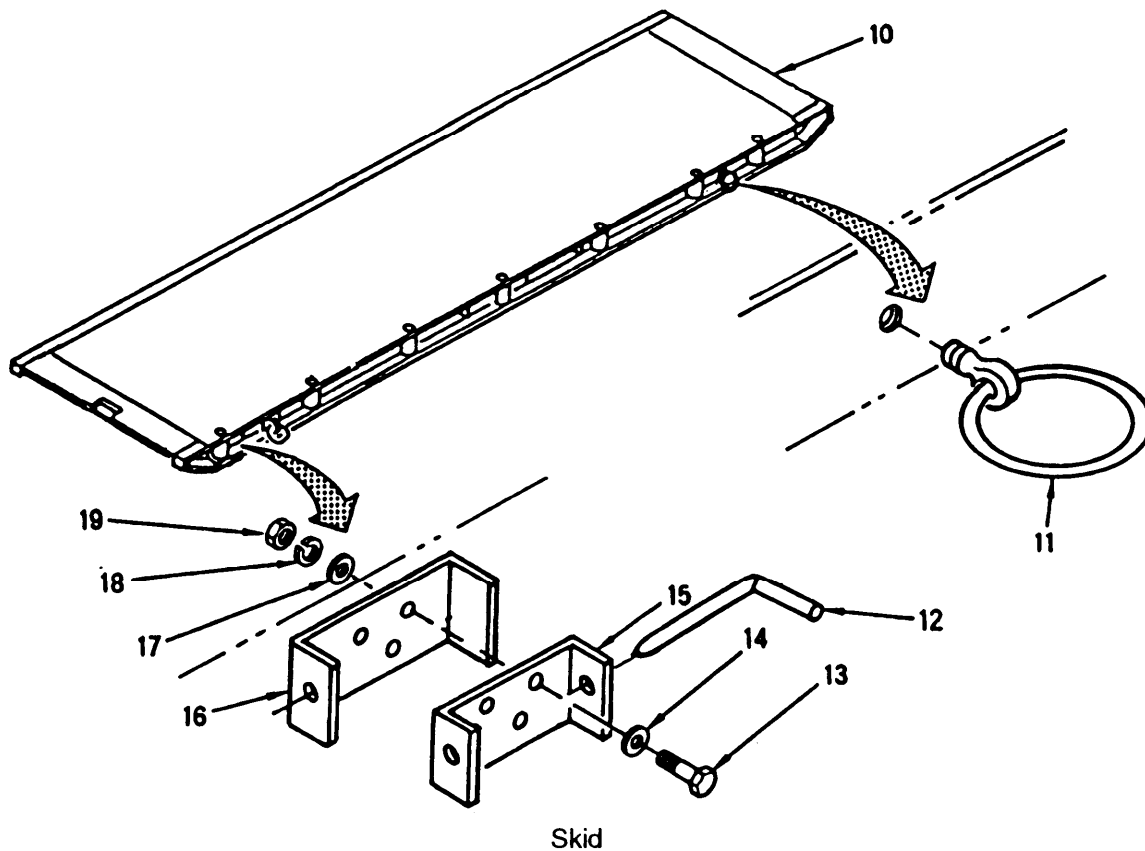

d. Assembly.

- (1) Position side panel (4) on skid (7). Lock four locking pins (6).
- (2) Repeat step (1) for other side panel (10).
- (3) Position end panel (9 and 13) between side panel (4 and 10). Turn four handles (8) to LOCK position on both end panels.
- (4) Position divider pan (2) on skid (7).
- (5) Lower top cover (1) onto water chest. Fasten eight latches (5).

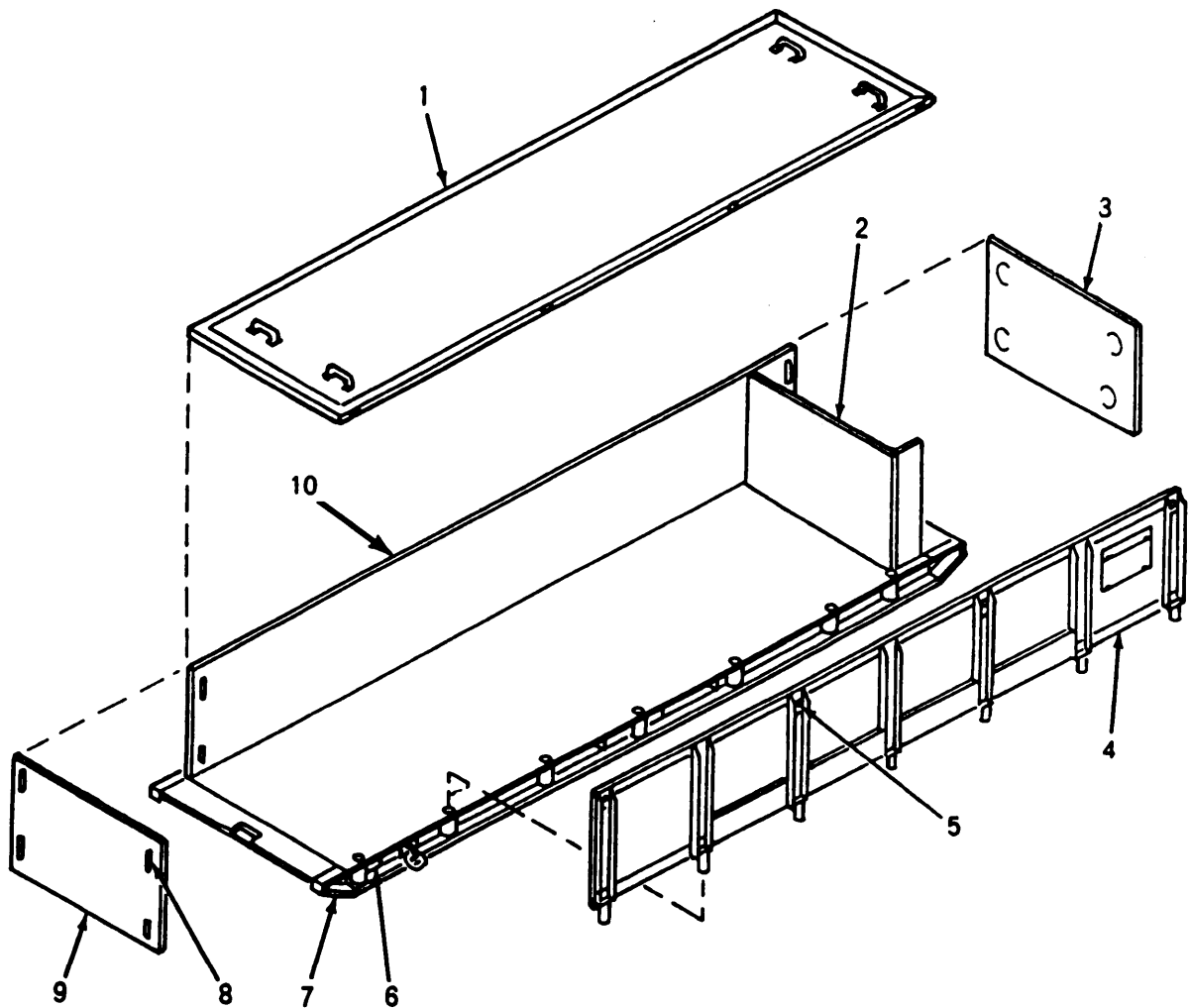

Water Tank Chest

Section VI. PREPARATION FOR STORAGE OR SHIPMENT

Procedure	Page
Removing Equipment From Service	4-52
Storage	4-52

4.35 REMOVING EQUIPMENT FROM SERVICE.

To prepare the equipment for storage, perform preparation for movement procedures contained in paragraph 2.13. Make sure all water is removed from hoses, couplings, and fittings.

4.36 STORAGE.

Storage area must protect the equipment from weather extremes. Temperature range for equipment in storage is -25°F to 125°F(-31°C to 51.7°C).

CHAPTER 5
DIRECT SUPPORT MAINTENANCE INSTRUCTIONS

	Page
Distribution Nozzle (1-inch) Repair.	5-1
Distribution Nozzle (1 1/2-inch) Repair.	5-14
General.	5-1
Water Pressure Regulator Assembly Repair.	5-6
Water Tank Chest Repair.	5-18

5.1 GENERAL.

This section contains procedures for maintaining components that are the responsibility of Direct Support Maintenance.

NOTE

Disassemble components only to the level required to effect repairs.

5.2 DISTRIBUTION NOZZLE (1-INCH) REPAIR.

This task consists of:	a. Disassembly	d. Repair
	b. Cleaning	e. Assembly
	c. Inspection	

INITIAL SET-UP:

Tools:

- Tool Kit, General Mechanics, Automotive (Appendix B, Sec. III, item 1)
- Vice (Appendix B, Sec. III, item 2)

Materials/Parts Required:

- Detergent General Purpose (Item 1, Appendix D)
 - Rag, Wiping (item 2, Appendix D)
 - Tape, Anti-seize (Item 3, Appendix D)
 - Gasket, Coupling - MS27030-1
 - Packing Ring - 231AW-02192P
 - Disc - 300ALM0408 2D
-

a. Disassembly.

- (1) Disconnect S-hook (22) from guard (21)
- (2) Remove S-hook (22) from chain (23)
- (3) Remove tube cap (25) and S-hook (24) from chain (23). Disconnect S-hook from tube cap.
- (4) Drive out hollow pins (18 and 20). Remove guard (17) from body (3).
- (5) Drive out hollow pin (19) and remove lever (16) from guard (21).
- (6) Remove gasket (11) from coupling half (10).
- (7) Remove swivel (9) and coupling half (10) from body (3).
- (8) Unscrew coupling half (10) From swivel (9).

5.2 DISTRIBUTION NOZZLE (1-INCH) REPAIR - continued.

- (9) Remove packing nut (14).
- (10) Pull stem (15) from body (3).
- (11) Remove packing gland (13) and packing ring (12).



Warning

Remove cap slowly. Spring tension may cause cap to fly off.

- (12) Remove cap (8) and spring (7).
 - (13) Remove poppet (6), disc (5) and disc nut (4) from body (3) and disassemble.
 - (14) Remove jam nut (2) and tube (1) from body (3).
 - (15) Remove jam nut (2) from tube (1).
- b. Cleaning.
- (1) Clean all components with clean water and detergent.
 - (2) Rinse components in clean water and dry with wiping rag.
- c. Inspection.
- (1) Inspect body (3) for cracks and stripped or damaged threads.
 - (2) Inspect guard (21) and lever (16) for cracks.
 - (3) Inspect tube (1) for bends, cracks and deformation.
 - (4) Inspect stem (15) for scoring. Check that stem is straight.

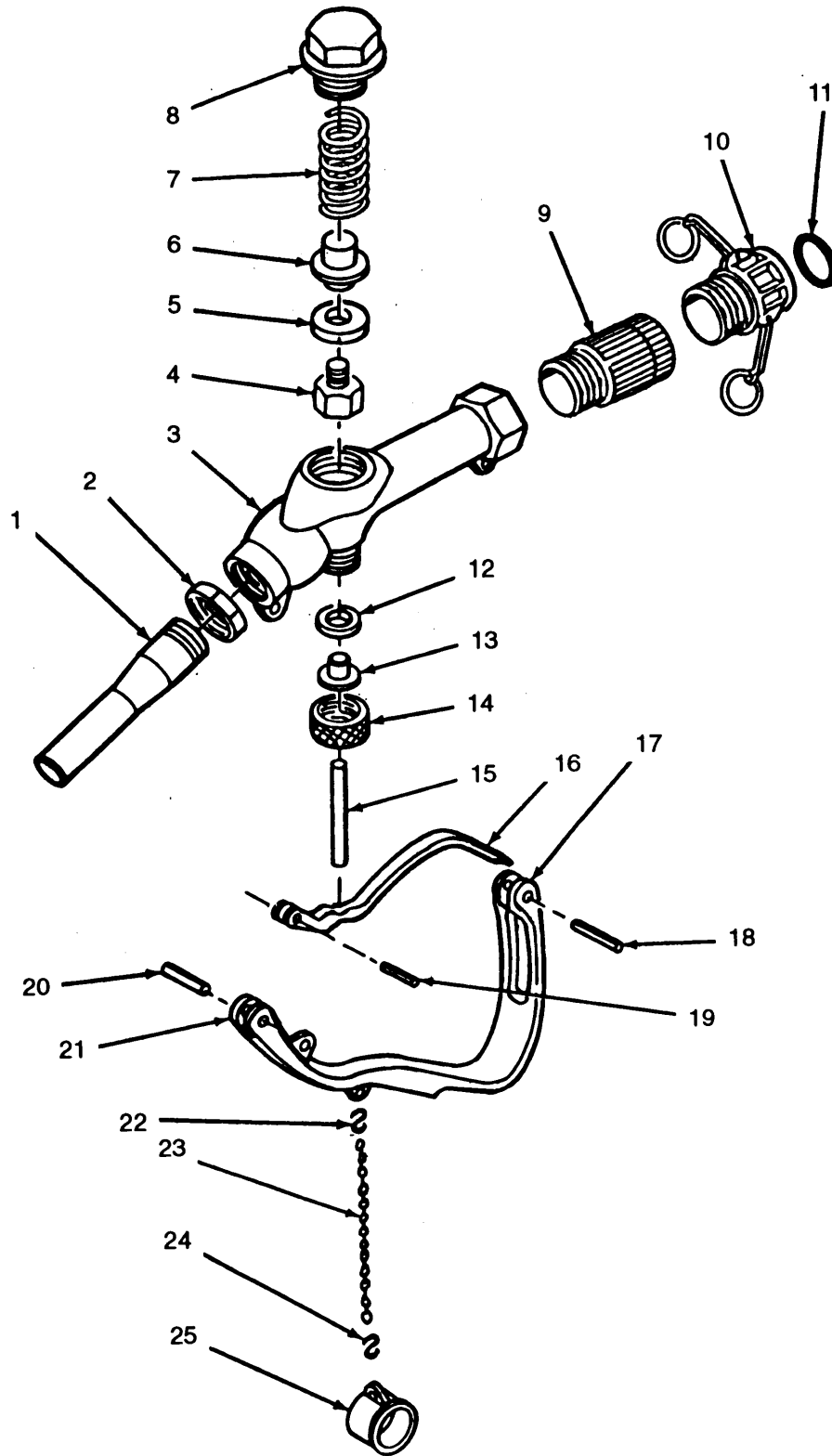

Distribution Nozzle (1-inch)

5.2 DISTRIBUTION NOZZLE (1-INCH) REPAIR - continued

d. Repair. Replace damaged parts and all sealing components.

e. Assembly.

- (1) Install jam nut (2) on tube (1).
- (2) Install tube (1) in body (3) and tighten jam nut (2).
- (3) Assemble disc nut (4), disc (5) and poppet (6) and install in body (3).
- (4) Install spring (7) and cap (8).
- (5) Install packing ring (12) and packing gland (13).
- (6) Push stem (15) into body (3).
- (7) Install packing nut (14).
- (8) Apply anti-seize tape to threads of coupling half (10). Screw coupling half into swivel (9).
- (9) Apply anti-seize tape to threads of swivel (9). Screw swivel and attached coupling half (10) into body (3).

NOTE

Ensure gasket is fully seated in groove of coupling.

- (10) Install gasket (11) in coupling half (10).
- (11) Position lever (16) on guard (21) and install hollow pin (19).

NOTE

Hollow pin (18) is longer than hollow pin (20).

- (12) Position guard (21) on body (3) and install two hollow pins (18 and 20).
- (13) Connect tube cap (25) to chain (23) with S-hook (24).
- (14) Connect chain (23) to body (3) with S-hook (22).

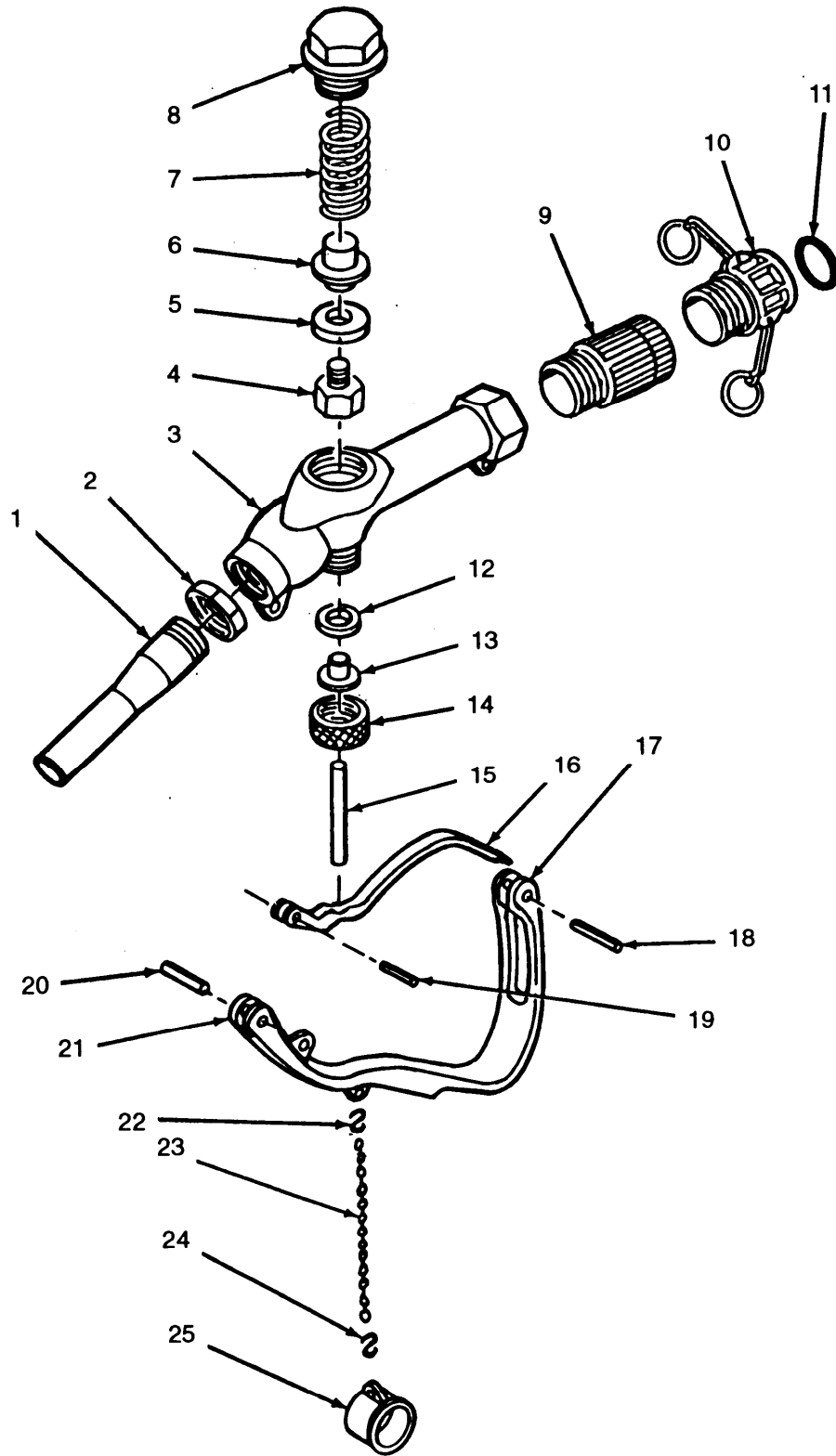

Distribution Nozzle (1-inch)

5.3 WATER PRESSURE REGULATOR ASSEMBLY REPAIR.

This task consists of:

- a. Disassembly
- b. Cleaning
- c. Inspection

- d. Repair
 - e. Assembly
-

INITIAL SET-UP:

Tools:

- Tool Kit, General Mechanics, Automotive (Appendix B, Sec. III, item 1)
- Vice (Appendix B, Sec. III, Item 2)

Materials/Parts Required:

- Detergent, General Purpose (Item 1, Appendix D)
 - Rag, Wiping (Item 2, Appendix D)
 - Tape, Anti-seize (Item 3, Appendix D)
 - Diaphragm - 1781
 - Gasket, Coupling - MS27030-1
-

a. Disassembly.

- (1) Remove four nuts (1) and washers (2).
- (2) Lift regulator assembly (3) from threaded rods (8).
- (3) Remove four nuts (13) and washers (12).
- (4) Remove four threaded rods (8) and attached parts from board (11).
- (5) Remove washers (6 and 10) and nuts (7 and 9) from threaded rods (8).
- (6) Remove coupling half (4) from regulator assembly (3).
- (7) Remove gasket (5) from coupling half.
- (8) Remove coupling half (14) from regulator assembly (3).

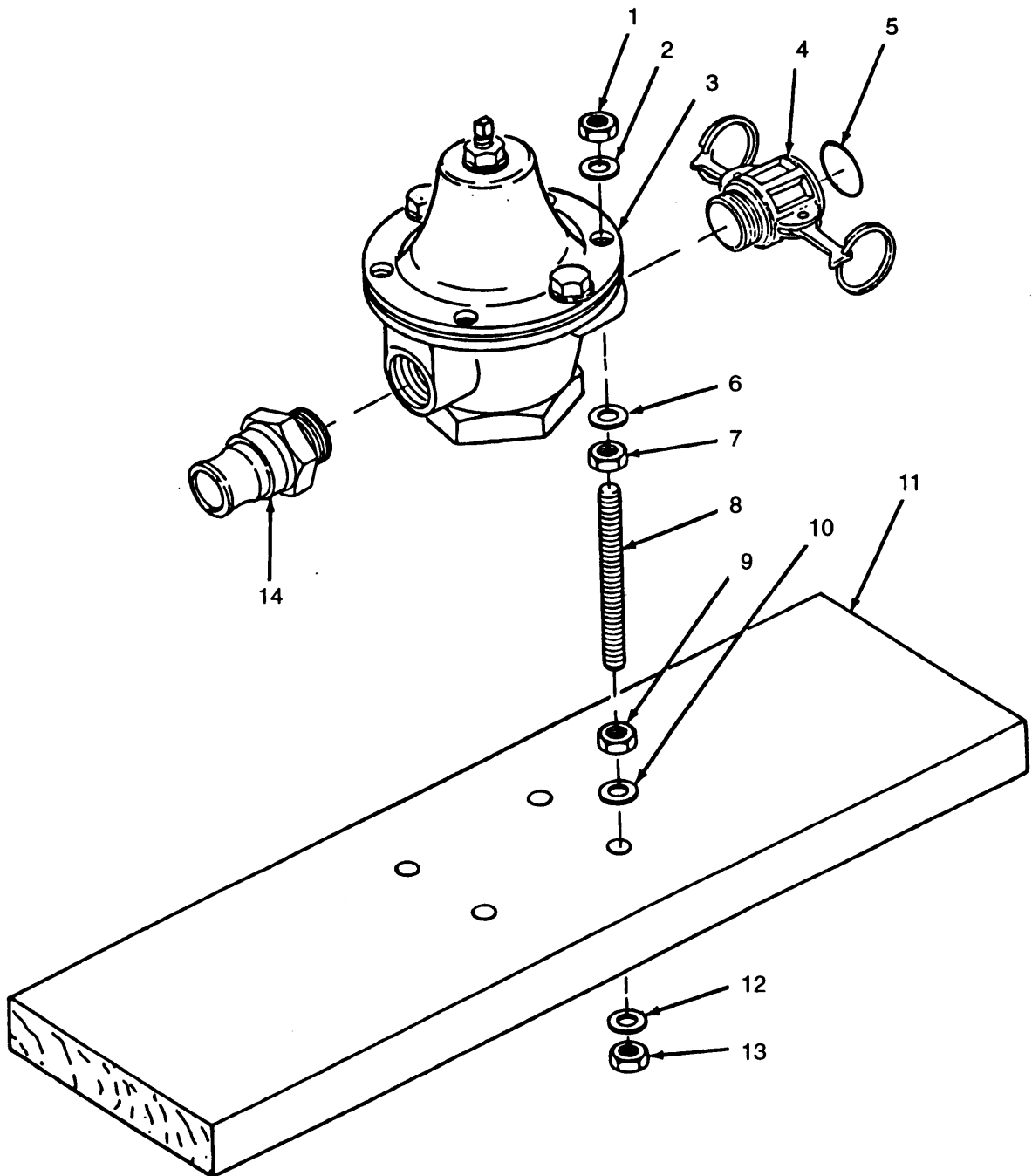

Water Pressure Regulator Assembly

5.3 WATER PRESSURE REGULATOR ASSEMBLY REPAIR - continued.

- (9) Loosen locknut (16).
- (10) Remove adjusting screw (15), locknut (16) and tag (17).
- (11) Remove two nuts (26) and screws (18).
- (12) Lift spring chamber (19) from body (25).
- (13) Remove spring button (20) and pressure spring (21).

NOTES

- Pressure plate is not secured to diaphragm.
 - Diaphragm consists of four metal discs.
- (14) Remove pressure plate (22) and diaphragm (23).
 - (15) Remove button (24).
 - (16) Position body (25) so that plug (32) is pointing down.

NOTE

Plug is under light spring tension.

- (17) Loosen plug (32) with wrench. Unscrew plug from body (25) by hand.
 - (18) Remove strainer screen (28), piston (29), and spring (30) from body (25).
 - (19) Remove cylinder (27) from body (25).
 - (20) Remove gasket (31) from plug (32).
- b. Cleaning.
- (1) Clean all components with clean water and detergent.
 - (2) Rinse components in clean water and dry with wiping rag.
- c. Inspection.
- (1) Inspect spring chamber (19) and body (25) for cracks, stripped threads and corrosion.
 - (2) Inspect diaphragm (23) for cuts, tears and holes.
 - (3) Inspect strainer screen (28) for tears and clogs.
 - (4) Inspect cylinder (27) and piston (29) for excessive wear.
 - (5) Inspect springs (21 and 30) for broken or bent coils.

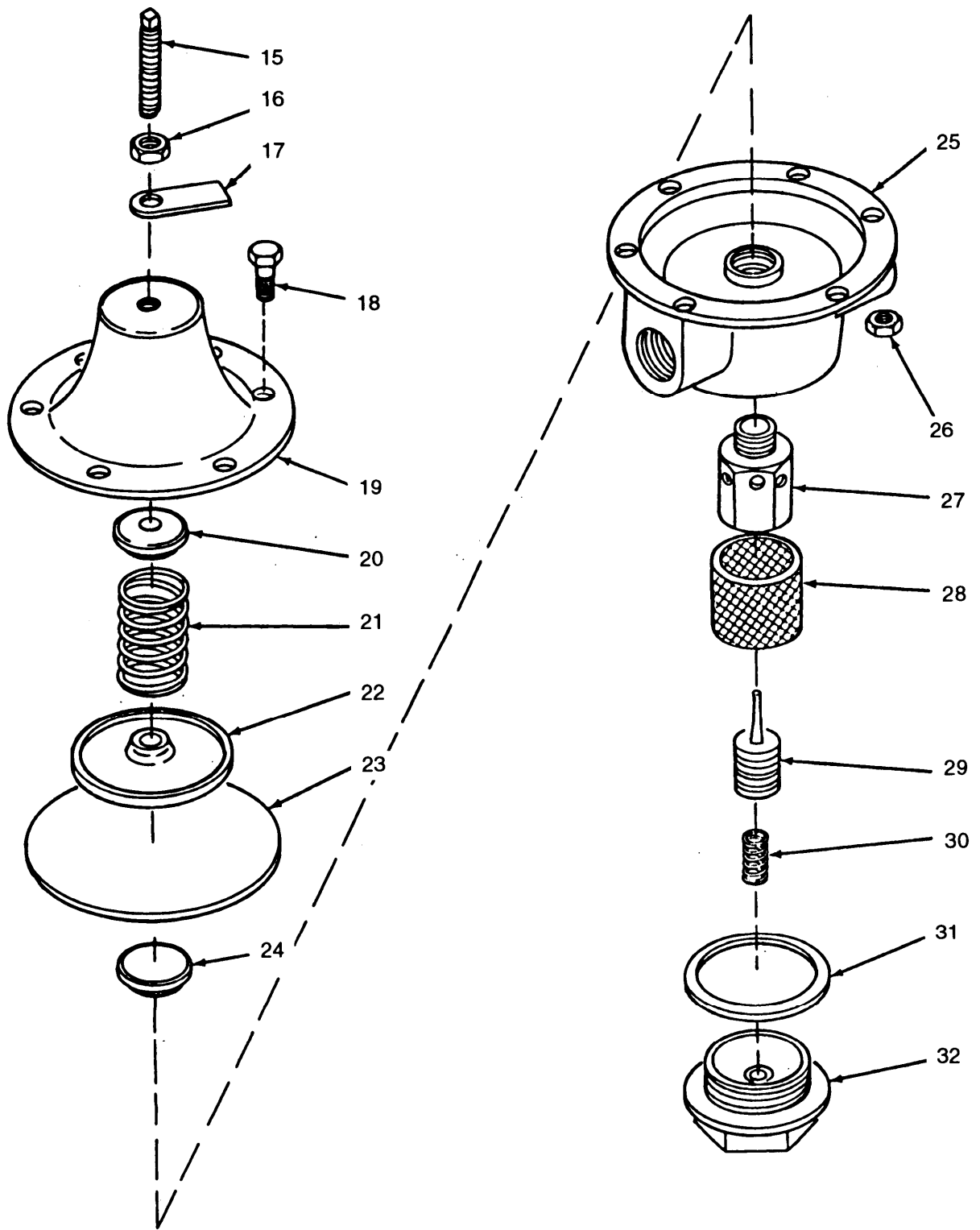

Water Pressure Regulator Valve

5.3 WATER PRESSURE REGULATOR ASSEMBLY REPAIR - continued

- d. Repair. Replace damaged parts and all sealing components. If piston (29) or cylinder (27) is worn, replace both components.
- e. Assembly.
 - (1) Install gasket (31) on plug (32).
 - (2) Install cylinder (27) on body (25).
 - (3) Position body (25) so that plug (32) opening is pointing down.
 - (4) Position strainer screen (28), piston (29), and spring (30) in body (25).
 - (5) Screw plug (32) and attached parts into body (25). Make sure parts fit into body correctly.
 - (6) Install button (24). Make sure button is centered on piston (29) post sticking up through cylinder (27).

NOTE

Diaphragm consists of four metal discs.

- (7) Position diaphragm (23) and pressure plate (22) on body (25).
- (8) Position pressure spring (21) and spring button (20) on pressure plate (22).
- (9) Lower spring chamber (19) onto body (25). Make sure pressure plate (22), spring (21) and spring button (20) remain centered on diaphragm (23).
- (10) Install two screws (18) and nuts (26).
- (11) Install tag (17), locknut (16) and adjusting screw (15).

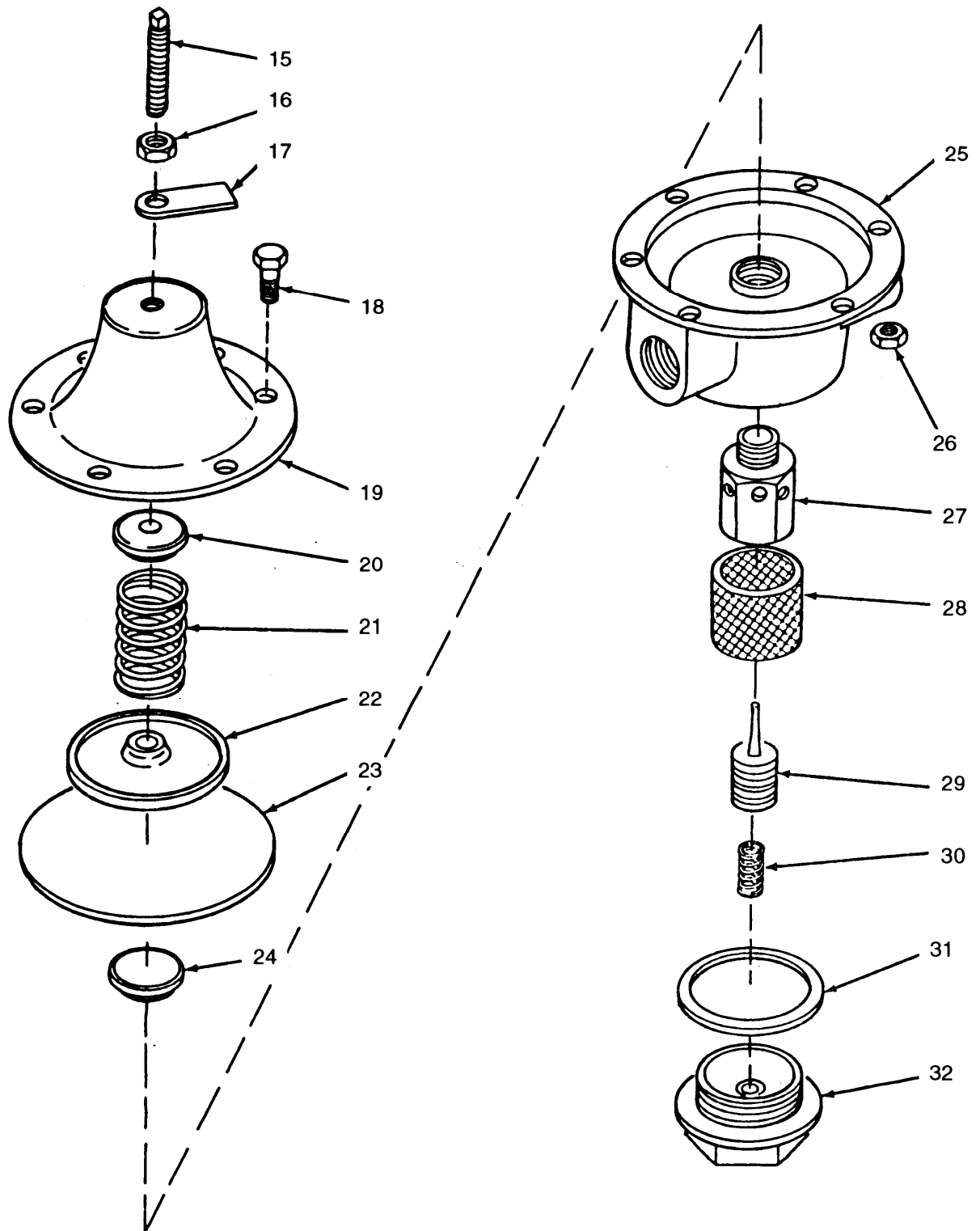

Water Pressure Regulator Valve

5.3 WATER PRESSURE REGULATOR ASSEMBLY REPAIR - continued.

- (12) Apply anti-seize tape to threads of coupling half (14). Install coupling half (14) on regulator assembly (3).

NOTES

- Ensure gasket is fully seated in groove of coupling half.
 - Ensure coupling half is installed on inlet side of regulator.
 - When installing coupling half, maintain enough space between coupling half and regulator so that locking arms will close when regulator is installed on threaded rods.
- (13) Install gasket (5) in coupling half (4).
- (14) Apply anti-seize tape to threads of coupling half (4). Install coupling half(4) on regulator assembly (3).
- (15) Install nuts (7 and 9) and washers (6 and 10) on threaded rods (8).
- (16) Position four threaded rods (8) and attached parts on board (11).
- (17) Install four washers (12) and nuts (13).
- (18) Lower regulator assembly (3) onto threaded rods (8).
- (19) Install four washers (2) and nuts (1).

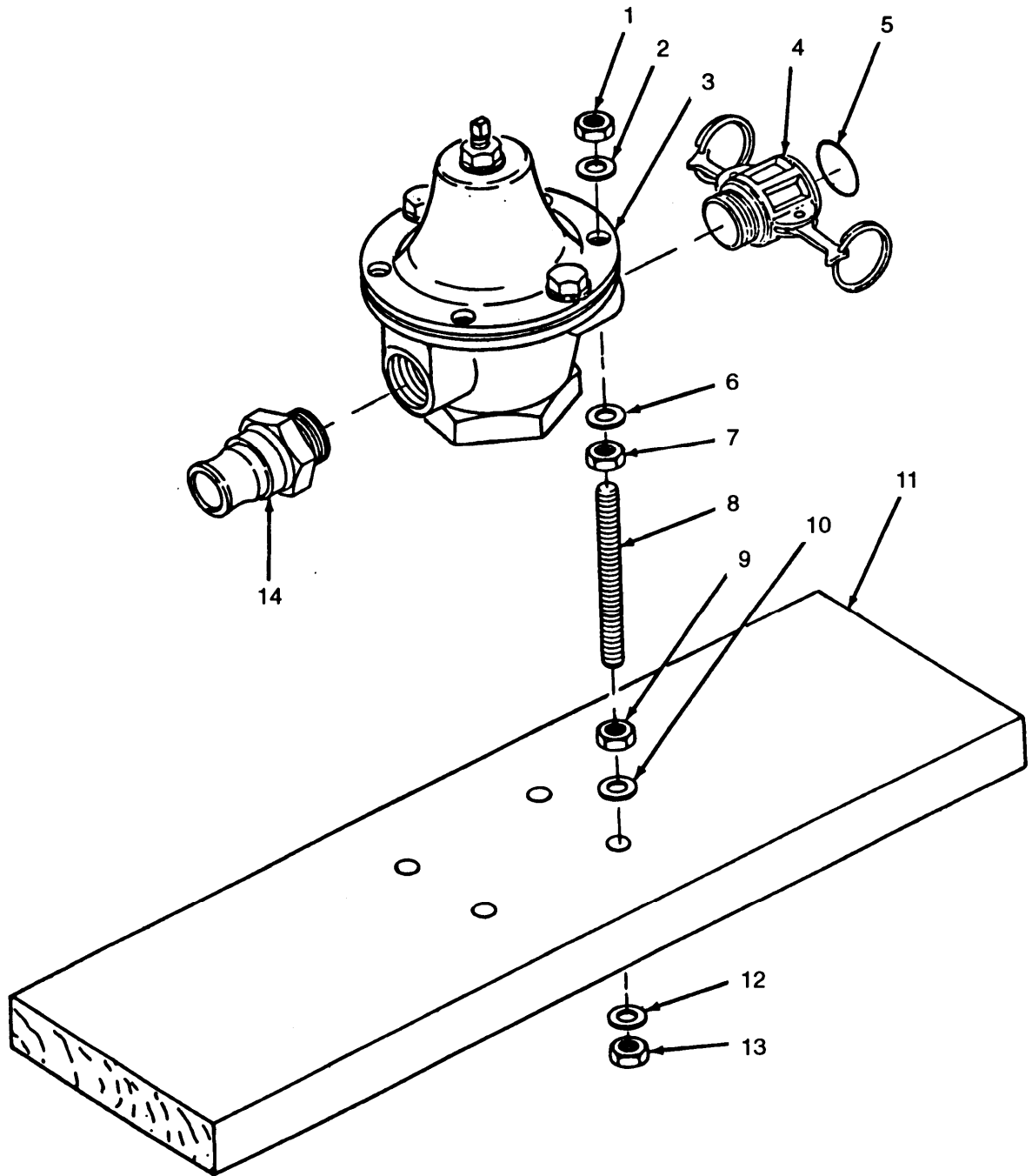

Water Pressure Regulator Assembly

5.4 DISTRIBUTION NOZZLE (11/2-INCH) REPAIR.

This task consists of:	a. Disassembly	d. Repair
	b. Cleaning	e. Assembly
	c. Inspection	

INITIAL SET-UP:

Tools:

Tool Kit, General Mechanics, Automotive (Appendix B, Sec. III, item 1)

Materials/Parts Required:

Detergent, General Purpose (Item 1, Appendix D)

Rag, Wiping (Item 2, Appendix D)

Tape, Anti-seize (Item 3, Appendix D)

a. Disassembly.

- (1) Disconnect S-hook (19) from body (14).
- (2) Remove S-hook (19) from chain and spring (20).
- (3) Remove tube cap (22) and S-hook (21) from chain and spring (20). Disconnect S-hook from tube cap.
- (4) Remove gasket (11) from coupling half (12).
- (5) Remove swivel (13) and coupling half (12) from body (14).
- (6) Unscrew coupling half (12) from swivel (13).
- (7) Drive out groove pin (24) and remove handle (25) from body (14).



Warning

Remove cap slowly. Spring tension may cause cap to fly off.

- (8) Remove cap (1), gasket (2), spring (3) and assembled components (4, 5, and 6). Disassemble disc holder (4), small disc (5) and disc guide (6).
- (9) Lift assembled components (7 through 10) from body (14).
- (10) Unscrew disc nut (10) from holder (7). Remove disc (8) and washer (9) from holder.
- (11) Pull stem (15) from body (14).
- (12) Remove packing nut (18) and packing gland (17).
- (13) Remove stuffing box (26) from body (14).
- (14) Remove packing (16) from stuffing box (26).
- (15) Unscrew tube and adapter (23) from body (14).

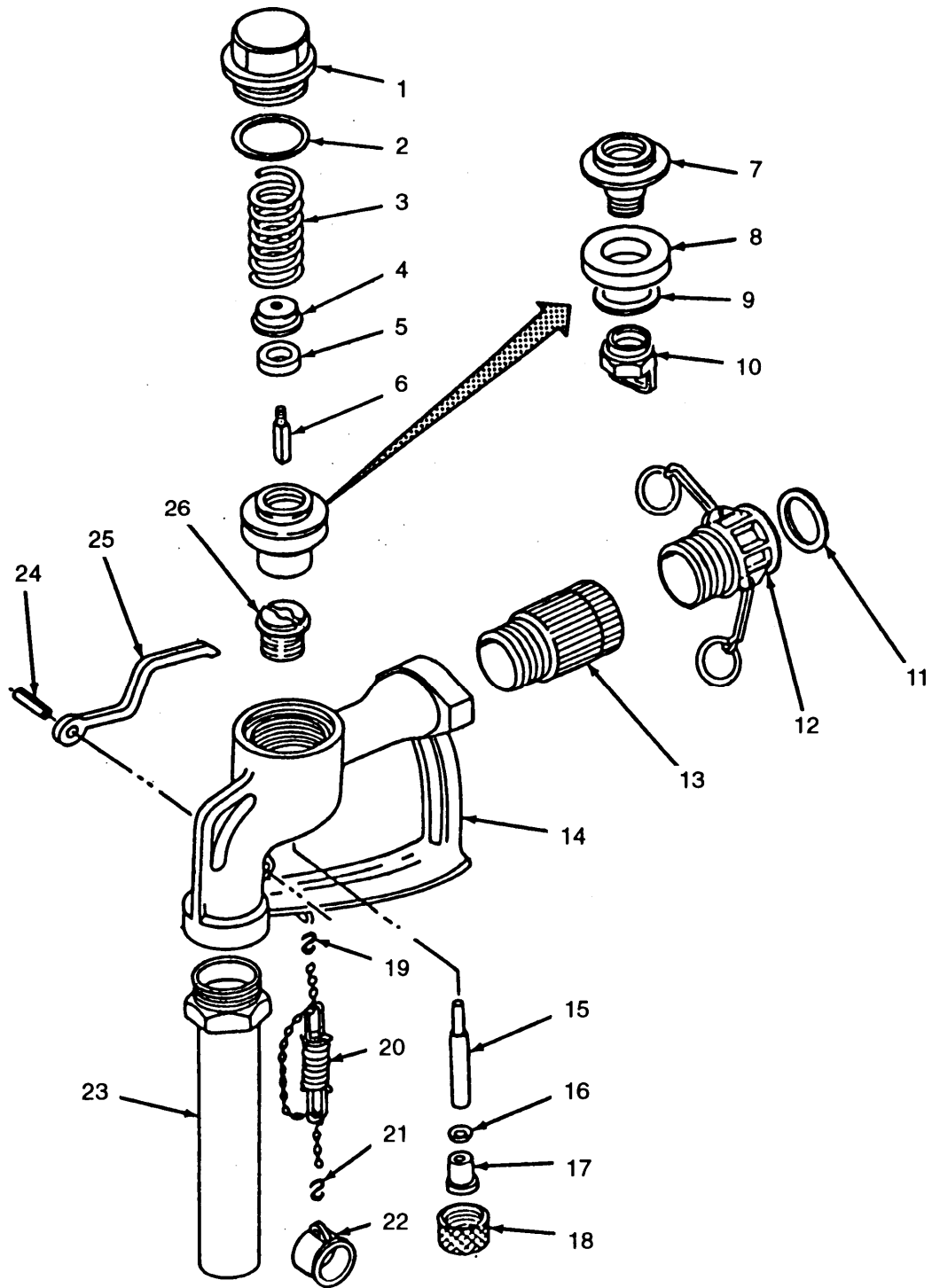

Distribution Nozzle (1 1/2-inch)

5.4 DISTRIBUTION NOZZLE (1 1/2-INCH) REPAIR - continued

b. Cleaning.

- (1) Clean all components with clean water and detergent.
- (2) Rinse components in clean water and dry with wiping rag.

c. Inspection

- (1) Inspect body (14) for cracks and stripped or damaged threads.
- (2) Inspect handle (25) for cracks.
- (3) Inspect tube and adapter (23) for bends, cracks and deformation.
- (4) Inspect stem (15) for scoring. Check that stem is straight.

d. Repair. Replace damaged parts and all sealing components.

e. Assembly.

- (1) Screw tube and adapter (23) into body (14).
- (2) Install packing (16) in stuffing box (26). Install stuffing box in body (14).
- (3) Install stem (15), packing gland (17) and packing nut (18) in body (14).
- (4) Position disc (8) and washer (9) on holder (7). Screw disc nut (10) onto holder (7).
- (5) Position assembled components (7 through 10) in body (14).
- (6) Assemble disc guide (6), small disc (5) and disc holder (4). Position assembled components (4, 5 and 6) in body (14).
- (7) Install spring (3), gasket (2) and cap (1) on body (14).
- (8) Position handle (25) on body (14) and install groove pin (24).
- (9) Apply anti-seize tape to threads of swivel (13) and coupling half (12).
- (10) Screw coupling half (12) into swivel (13).
- (11) Install swivel (13) and attached coupling half (12) on body (14).
- (12) Install gasket (11) in coupling half (12).
- (13) Connect tube cap (22) to chain and spring (20) with S-hook (21).
- (14) Connect chain and spring (23) to body (14) with S-hook (19).

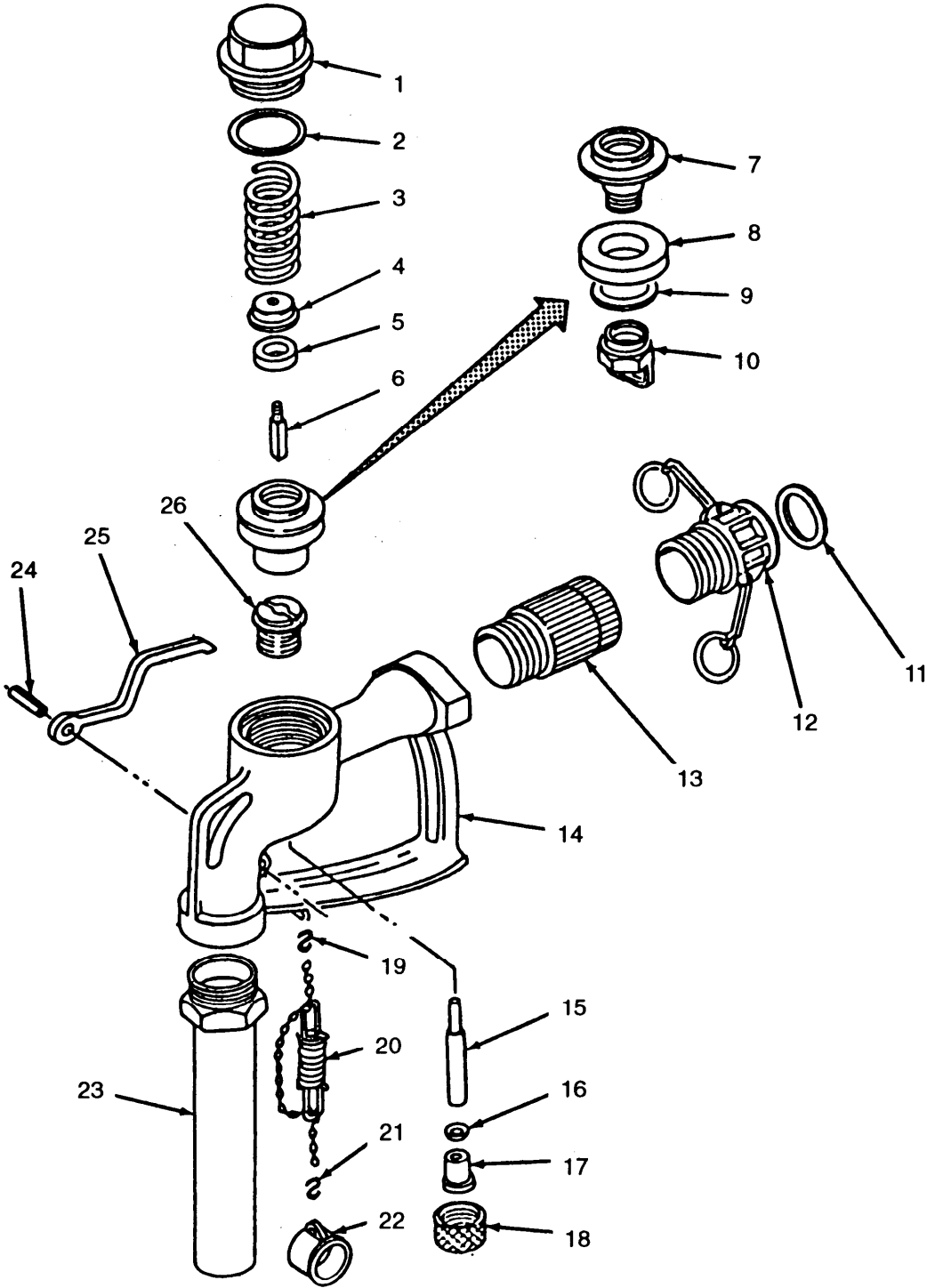

Distribution Nozzle (1 1/2-inch)

5.5 WATER TANK CHEST REPAIR.

This task consists of: Repair

INITIAL SET-UP:

Tools:

Welding Shop (Appendix B, Sec. III, Item 3)

Materials/Parts Required:

Detergent, General Purpose (Item 1, Appendix D)

Rag, Wiping (Item 2, Appendix D)

Gasket (roll) -22036-9 (for top cover)

Gasket (roll) -22036-8 (for end panel)

Gasket (roll) (for side panel)

References:

TM 9-237 Welding Theory and Application

TM 43-0139 Painting Instructions for Army Materiel

Repair.

- a. Inspect for cracks, broken latches and handles, and broken frame parts.
- b. Weld water tank chest as required in accordance with TM 9-237.
- c. Paint water tank chest in accordance with TM 43-0139.

**APPENDIX A
REFERENCES**

A.1 SCOPE.

This appendix lists all forms, field manuals, technical manuals, and miscellaneous publications referenced in this manual.

A.2 FORMS.

Equipment Control Record	DA Form 2408-9
Equipment Inspection and Maintenance Worksheet	DA Form 2404
Quality Deficiency Report	SF368
Recommended Changes to DA Publications	DAForm2028-2
Recommended Changes to Publications and Blank Forms	DAForm 2028
Report of Discrepancy	SF 364

A.3 FIELD MANUALS.

First Aid for Soldiers	FM 21-11
----------------------------------	----------

A.4 MISCELLANEOUS.

Consolidated Index of Army Publications and Blank Forms	DA PAM 25-30
Destruction of Army Materiel to Prevent Enemy Use	TM750-224-3
Operator's and Unit Maintenance Manual for 20,000 Gallon Collapsible Fabric Tank.	TM5-5430-226-12
Operator's, Unit and Direct Support Maintenance Manual Including Repair Parts and Special Tools List for Hypochlorination Unit	TM 5-4610-233-13&P
Unit and Direct Support Maintenance Repair Parts and Special Tools List for 40,000 Gallon Water Distribution System	TM10-4610-234-23P
Operator's, Unit, Direct Support and General Support Maintenance Manual for 125 GPM Pump Assembly	TM 5-4320-304-14
Operator's, Unit, Direct Support and General Support Maintenance Manual for 125 GPM Pump Assembly	TM10-4320-309-14
Operator's, Unit, Direct Support and General Support Maintenance Manual for 350 GPM Pump Assembly	TM 5-4320-226-14
Painting Instructions for Army Materiel	TM 43-0139
The Army Maintenance Management System (TAMMS)	DA PAM 738-750
Unit Maintenance Repair Parts and Special Tools List for 20,000 Gallon Collapsible Fabric Tank	TM5-5430-226-20P
Welding Theory and Application	TM 9-237

APPENDIX B MAINTENANCE ALLOCATION CHART

Section I. INTRODUCTION

B.1 GENERAL.

- a. This section provides a general explanation of all maintenance and repair function authorized at various maintenance categories.
- b. The Maintenance Allocation Chart (MAC) in Section II designates overall authority and responsibility for performance of maintenance functions on the identified end item or component. The application of the maintenance functions to the end item or component will be consistent with the capacities and capabilities of the designated maintenance categories.
- c. Section III lists the tools and test equipment (both special tools and common tool sets) required for each maintenance function as referenced from Section II.
- d. Section IV contains supplemental instructions and explanatory notes for a particular maintenance function.

B.2 MAINTENANCE FUNCTIONS.

Maintenance functions will be limited to and are defined as follows:

- a. Inspect. To determine the serviceability of an item by comparing its physical, mechanical, and/or electrical characteristics with established standards through examination (e.g., by sight, sound, or feel).
- b. Test. To verify serviceability by measuring the mechanical, pneumatic, hydraulic, or electrical characteristics of an item and comparing those characteristics with prescribed standards.
- c. Service. Operations required periodically to keep an item in proper operating condition, i.e., to lean (includes decontaminate, when required), to preserve, to drain, to paint, or to replenish fuel, lubricants, chemical fluids, or gases.
- d. Adjust. To maintain or regulate, within prescribed limits, by bringing into proper or exact position, or by setting the operating characteristics to specified parameters.
- e. Align. To adjust specified variable elements of an item to bring about a optimum performance.
- f. Calibrate. To determine and cause corrections to be made or to be adjusted on instruments or test, measuring, and diagnostic equipments used in precision measurement. Consists of comparisons of two instruments, one of which is a certified standard of known accuracy, to detect and adjust any discrepancy in the accuracy of the instrument being compared.
- g. Remove/Install. To remove and install the same item when required to perform service or other maintenance functions. Install may be the act of emplacing, seating, or fixing into position a spare, repair part, or module (component or assembly) in a manner to allow the proper functioning of an equipment or system.

B.2 MAINTENANCE FUNCTIONS - continued.

- h. Replace. To remove an unserviceable item and install a serviceable counterpart in its place. "Replace" is authorized by the MAC and is shown as the 3rd position code of the SMR code.
- i. Repair. The application of maintenance services, including fault location/troubleshooting, removal/installation, and disassembly/assembly procedures, and maintenance actions to identify troubles, and restore serviceability to an item by correcting specific damage, fault, malfunction, or failure in a part, subassembly, module (component or assembly) end item, or system.
- j. Overhaul. That maintenance effort (service/action) prescribed to restore an item to a completely serviceable/operational condition as required by maintenance standards in appropriate technical publications (i.e., DMWR). Overhaul is normally the highest degree of maintenance performed by the Army. Overhaul does not normally return an item to like new condition.
- k. Rebuild. Consists of those service/actions necessary for the restoration of unserviceable equipment to a like new condition in accordance with original manufacturing standards. Rebuild is the highest degree of material maintenance applied to Army equipment. The rebuild operation includes the act of returning to zero those age measurements (hour/miles, etc.) considered in classifying Army equipment/components.

B.3 EXPLANATION OF COLUMNS IN THE MAC - SECTION II.

- a. Column 1. Group Number. Column 1 lists functional group code numbers, the purpose of which is to identify maintenance significant components, assemblies, subassemblies, and modules with the next higher assembly. End item group numbers are "00".
- b. b. Column 2. Component/Assembly. Column 2 contains the names of components, assemblies, subassemblies, and modules for which maintenance is authorized.
- c. Column 3. Maintenance Function. Column 3 lists the functions to be performed on the item listed in Column 2. (For a detailed explanation of these functions, see paragraph B-2).
- d. Column 4. Maintenance Level. Column 4 specifies, by the listing of a work time figure (expressed as man-hours shown as whole hours or decimals) in the appropriate subcolumn(s), the level of maintenance authorized to perform the function listed in Column (3). This figure represents the active time required to perform that maintenance function at the indicated level of maintenance. If the number or the complexity of the tasks within the listed maintenance function vary at different maintenance levels, appropriate work time figures will be shown for each level. The work time figure represents the average time required to restore an item (assembly, subassembly, component, module, end item, or system) to a serviceable condition under typical field operating conditions. This time includes preparation item including any necessary disassembly/assembly time), troubleshooting/fault location time, and quality assurance/quality control time in addition to the time required to perform the specific tasks identified for the maintenance functions authorized in the maintenance allocation chart. The system designations for the various maintenance levels are shown on the following page.

C	Operator or crew
O	Unit Maintenance
F	Direct Support Maintenance
H	General Support Maintenance
D	Depot Maintenance

- e. Column 5. Tools and Equipment. Column 5 specifies, by code, those common tool sets (not individual tools) common TMDE, and special tools, special TMDE, and support equipment required to perform the designated function.
- f. Column 6. Remarks. This column, when applicable, contains a letter code, in alphabetic order, which is keyed to the remarks contained in Section IV.

B.4 EXPLANATION OF COLUMNS IN TOOL AND TEST EQUIPMENT REQUIREMENTS. SECTION III.

- a. Column 1. Reference Code. The tool and test equipment reference code correlates with a code used in the MAC, Section II, Column 5.
- b. Column 2. Maintenance Level. The lowest category of maintenance authorized to use the tool or test equipment.
- c. Column 3. Nomenclature. Name or identification of the tool or test equipment.
- d. Column 4. National Stock Number. The national stock number of the tool or test equipment.
- e. Column 5. T001 Number. The manufacturer's part number.

B.5 EXPLANATION OF COLUMNS IN REMARKS. SECTION IV.

- a. Column 1. Reference Code. The code recorded in column 6, Section II.
- b. Column 2. Remarks. This column lists information pertinent to the maintenance function being performed as indicated in the MAC, Section II.

Section II. MAINTENANCE ALLOCATION CHART

(1) GROUP NUMBER	(2) COMPONENT/ ASSEMBLY	(3) MAINTENANCE FUNCTION	(4) MAINTENANCE LEVEL					(5) TOOLS AND EQUIPMENT	(6) REMARKS
			UNIT		DS	GS	DEPOT		
			C	O	F	H	D		
00	40,000 Gallon Water Storage and Water Storage and Distribution System								
01	Bag Filler Connection Kit								
0101	Discharge Hose, 1-1/2 inch	Inspect Replace Repair	0.1 0.2 1.0					1, 2	
0102	Gate Valve Assembly, 2-inch	Inspect Replace Repair	0.1 0.2 1.5					1, 2	
0103	Discharge Hose 2-inch	Inspect Replace Repair	0.1 0.2 1.0					1, 2	
0104	Tee Assembly	Inspect Replace Repair	0.1 0.2 1.0					1	
0105	Discharge Hose, 4-inch	Inspect Replace Repair	0.1 0.2 1.0						
0106	Hose and Nozzle Kit								
010601	Distribution Nozzle (1-inch)	Inspect Replace Repair	0.1 0.2		1.0			1, 2	
010602	Discharge Hose, 1-inch	Inspect Replace Repair	0.1 0.2 1.0					1, 2	
010603	Water Pressure Regulator Assembly	Inspect Replace Repair Adjust	0.1 0.2 0.3		1.5			1, 2 1, 2	
010604	Nozzle Stand Assembly	Inspect Replace Repair	0.1 0.2 1.5					1	

Section II. MAINTENANCE ALLOCATION CHART - continued.

(1) GROUP NUMBER	(2) COMPONENT/ ASSEMBLY	(3) MAINTENANCE FUNCTION	(4) MAINTENANCE LEVEL					(5) TOOLS AND EQUIPMENT	(6) REMARKS
			UNIT		DS	GS	DEPOT		
			C	O	F	H	D		
02	Hose Nozzle Connection Kit								
0201	Distribution Nozzle (1-1/2-inch)	Inspect Replace Repair	0.1	0.2	1.0			1, 2	
0202	Discharge Hose, 1-1/2-inch	Inspect Replace Repair	0.1	0.2 1.0				1, 2	
0203	Discharge Hose, 2-inch	Inspect Replace Repair	0.1	0.2 1.0				1, 2	
0204	Gate Valve, 2-inch	Inspect Replace Repair	0.1	0.2 1.5				1, 2	
0205	Tee Assembly	Inspect Replace Repair	0.1	0.2 1.0				1	
0206	Discharge Hose, 4-inch	Inspect Replace Repair	0.1	0.2 1.0				1, 2	
0207	Nozzle Stand Assembly	Inspect Replace Repair	0.1	0.2 1.5				1	
03	Hose, Connection Kit, 2-inch								
0301	Discharge Hose, 2-inch	Inspect Replace Repair	0.1	0.2 1.0				1,2	
0302	Gate Valve, 2-inch	Inspect Replace Repair	0.1	0.2 1.5				1,2	
0303	Tee Assembly, 4-inch	Inspect Replace Repair	0.1	0.2 1.0				1	
0304	Discharge Hose, 4-inch	Inspect Replace Repair	0.1	0.2 1.0				1, 2	

Section II. MAINTENANCE ALLOCATION CHART - continued.

(1) GROUP NUMBER	(2) COMPONENT/ ASSEMBLY	(3) MAINTENANCE FUNCTION	(4) MAINTENANCE LEVEL					(5) TOOLS AND EQUIPMENT	(6) REMARKS
			UNIT		DS	GS	DEPOT		
			C	O	F	H	D		
0305	Nozzle Stand	Inspect Replace Repair	0.1						
04	Hypochlorination Unit			0.2				1	B
05	350 GPM Connection Kit			1.5					
0501	Tee Assemblies, 4-inch, FxFxM	Inspect Replace Repair	0.1	0.2 1.0				1	
0502	Tee Assemblies, 4-inch, FxFxM	Inspect Replace Repair	0.1	0.2 1.0				1	
0503	Tee Assemblies, 4-inch, FxFxM	Inspect Replace Repair	0.1	0.2 1.0				1	
0504	Tee Assemblies, 4-inch, FxFxM	Inspect Replace Repair	0.1	0.2 1.0				1	
0505	Suction Hose, 4-inch	Inspect Replace Repair	0.1	0.2 1.0				1	
0506	Gate Valve, 4-inch	Inspect Replace Repair	0.1	0.2 1.5				1, 2	
0507	Discharge Hose, 4-inch	Inspect Replace Repair	0.1	0.2 1.0				1, 2	
0508	Water Meter Assembly	Inspect Replace Repair	0.1	0.2 1.0				1	
06	Pumping Assembly, 350 GPM								D
07	125 GPM Connection Kit								
0701	Discharge Hose, 2-inch	Inspect Replace Repair	0.1	0.2 1.0				1, 2	

Section II. MAINTENANCE ALLOCATION CHART- continued.

(1) GROUP NUMBER	(2) COMPONENT/ ASSEMBLY	(3) MAINTENANCE FUNCTION	(4) MAINTENANCE LEVEL					(5) TOOLS AND EQUIPMENT	(6) REMARKS
			UNIT		DS	GS	DEPOT		
			C	O	F	H	D		
0702	Gate Valve, 2-inch	Inspect	0.1						
		Replace		0.2					
		Repair		1.5				1, 2	
0703	Check Valve, 2-inch	Inspect	0.1						
		Replace		0.2					
		Repair		1.0				1,2	
0704	Suction hose, 2-inch	inspect	0.1						
		Replace		0.2					
		Repair		1.0				1, 2	
08	Pump Assembly, 125 GPM							C	
09	Dual Tank Connection Kit								
0901	Discharge Hose, 4-inch, 10 ft.	Inspect	0.1						
		Replace		0.2					
		Repair		1.0				1, 2	
0902	Discharge Hose, 4-inch, 20 ft.	Inspect	0.1						
		Replace		0.2					
		Repair		1.0				1, 2	
0903	Tee and Gate Valve Assembly, 4-inch	Inspect	0.1						
		Replace		0.2					
		Repair		2.0				1, 2	
0904	Suction Hose, 4-inch, 20 ft.	Inspect	0.1						
		Replace		0.2					
		Repair		2.0				1, 2	
0905	Suction Hose, 4-inch, 10 ft.	Inspect	0.1						
		Replace		0.2					
		Repair		2.0				1, 2	
10	Tank, Fabric, Collapsible, 20,000 Gallon							A	
11	Accessory Kit	Replace		0.2				E	
12	Water Tank Chest	Inspect	0.1						
		Replace		0.3					
		Repair		1.0	3.0			1,3	

Section III. TOOLS AND TEST EQUIPMENT REQUIREMENTS

(1) REF- ERENCE CODE	(2) MAINTENANCE CATEGORY	(3) NOMENCLATURE	(4) NATIONAL STOCK NUMBER (NSN)	(5) TOOL NUMBER
1	O	Tool Kit, General Mechanics	5180-00-177-7033	SC5180-90-CL-N26
2	O	Shop Set, Automotive Vehicle	4910-00-754-0654	SC-4910-95-CL-A72
3	F	Welding Shop, Trailer Mounted	3431-01-090-1231	SC-3431-95-CL-A04

Section IV. REMARKS

REFERENCE CODE	REMARKS
A	Refer to TM 5-5430-226-12
B	Refer to TM 5-461-233-13&P
C	Refer to TM 5-4320-304-14 or TM 10-4320-309-14
D	Refer to TM 5-4320-226-14
E	Repair limited to replacement of kit component.

APPENDIX C COMPONENTS OF END ITEM AND BASIC ISSUE ITEMS LIST

Section I. INTRODUCTION

C.1 SCOPE.

This appendix lists components of end item and basic issue items for the 40K Water Distribution System to help you inventory items required for safe and efficient operation.

C.2 GENERAL.

The Components of End Item and Basic Issue Items List are divided into the following sections:

- a. Section II. Components of End Item. This listing is for informational purposes only, and is not authority to requisition replacements. These items are part of the end item, but are removed and separately packaged for transportation or shipment. As part of the end item, these items must be with the end item whenever it is issued or transferred between property accounts. Illustrations are furnished to assist you in identifying the items.
- b. Section III. Basic Issue Items. These are the minimum essential items required to place the 40K Water Distribution System in operation, to operate it, and to perform emergency repairs. Although shipped separately packaged, BII must be with the distribution system during operation and whenever it is transferred between property accounts. The illustrations will assist you with hard-to-identify items. This manual is your authority to request/requisition replacement BII, based on TOE/MTOE authorization of the end item.

C.3 EXPLANATION OF COLUMNS.

The following provides an explanation of columns found in the tabular listing:

- a. Column (1) Illustration Number (Illus Number). This column indicates the number of the illustration in which the item is shown.
- b. Column (2) - National Stock Number. Indicates the national stock number assigned to the item and will be used for requisitioning purposes.
- c. Column (3) - Description. Indicates the Federal item and name and, if required, a minimum description to identify and locate the item. The last line for each item indicates the CAGE (in parentheses) followed by the part number.
- d. Column (4) - Unit of Measure (U/M). Indicates the measure used in performing the actual operational/maintenance function. This measure is expressed by a two-character alphabetical abbreviation (e.g., ea, in, pr).
- e. Column (5) Quantity required (Qty rqd). Indicates the quantity of the item authorized to be used with/on the equipment.

Section II. COMPONENTS OF END ITEM

(1) Illus Number	(2) National Stock Number	(3) Description CAGEC and Part Number	(4) Usable On Code U/I	(5) Qty rqr
1	4610-01-120-7527	ACCESSORY KIT, 40,000 GAL SYSTEM (97403) 13225E9126	EA	1
2	5430-00-066-1235	ADAPTER ASSY, FUEL DRUM (97403) 13211E7541	EA	3
3	7240-00-025-3377	CAN, GAS, MILITARY, 5GAL (97403) MIL-C-1283	EA	8
4		CASE, COLOR COMPARATOR (97403) 13216E9016	EA	1
5	5430-01-168-0589	CHEST, WATER TANK - 50K (97403)22000-601	EA	2
6		COMPARATOR, COLOR (97403) 13200E7400	EA	1
7	4610-01-120-7528	CONNECTION KIT, BAG FILLER (97403) 13225E9111	EA	1
8	4320-01-120-7524	CONNECTION KIT, 125 GPM PUMP (97403) 13225E9113	EA	2
9	4320-01-120-7523	CONNECTION KIT, 350 GPM PUMP (97403) 13225E9112	EA	1
10	4610-01-120-7526	CONNECTION KIT, DUAL TANK (97403) 13225E9114	EA	1
11	4610-01-123-7526	CONNECTION KIT, HOSE NOZZLE (97403) 13225E9117	EA	4
12	4610-01-140-7705	CONNECTION KIT, HOSE, 2-INCH (97403) 13225E9132	EA	8
13		COTTON DUCK CASE (97403) MIL-P-11743	EA	1
14	4610-00-269-0163	HYPOCHLORINATION UNIT/BYPASS (97403) MIL-P-12732	EA	1
15	4310-01-156-3873	PUMP, 125 GPM AT 50' TDH (97403) MIL-P-52109	EA	2
16	4310-00-060-7853	PUMP, 350 GPM AT275' TDH (97403) MIL-P-52144	EA	1
17	7240-00-177-6154	SPOUT, CAN, FLEXIBLE (97403) MIL-S-1285	EA	4
18	5430-01-106-9678	TANK, FABRIC COLLAPSIBLE (97403) MIL-T-53029	EA	3

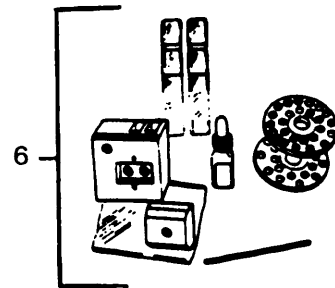
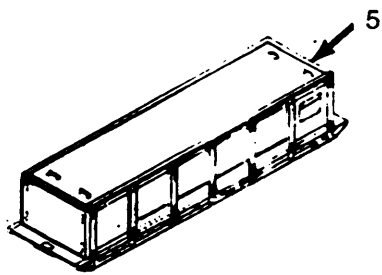
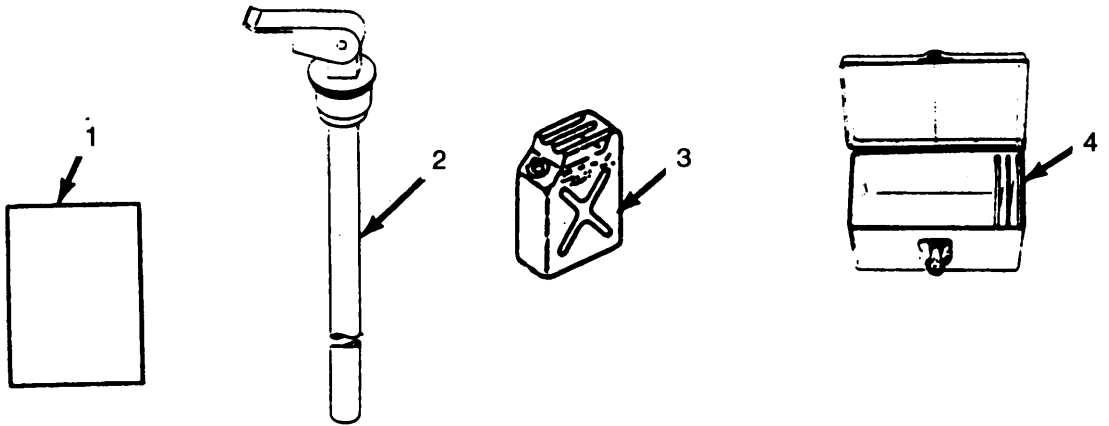

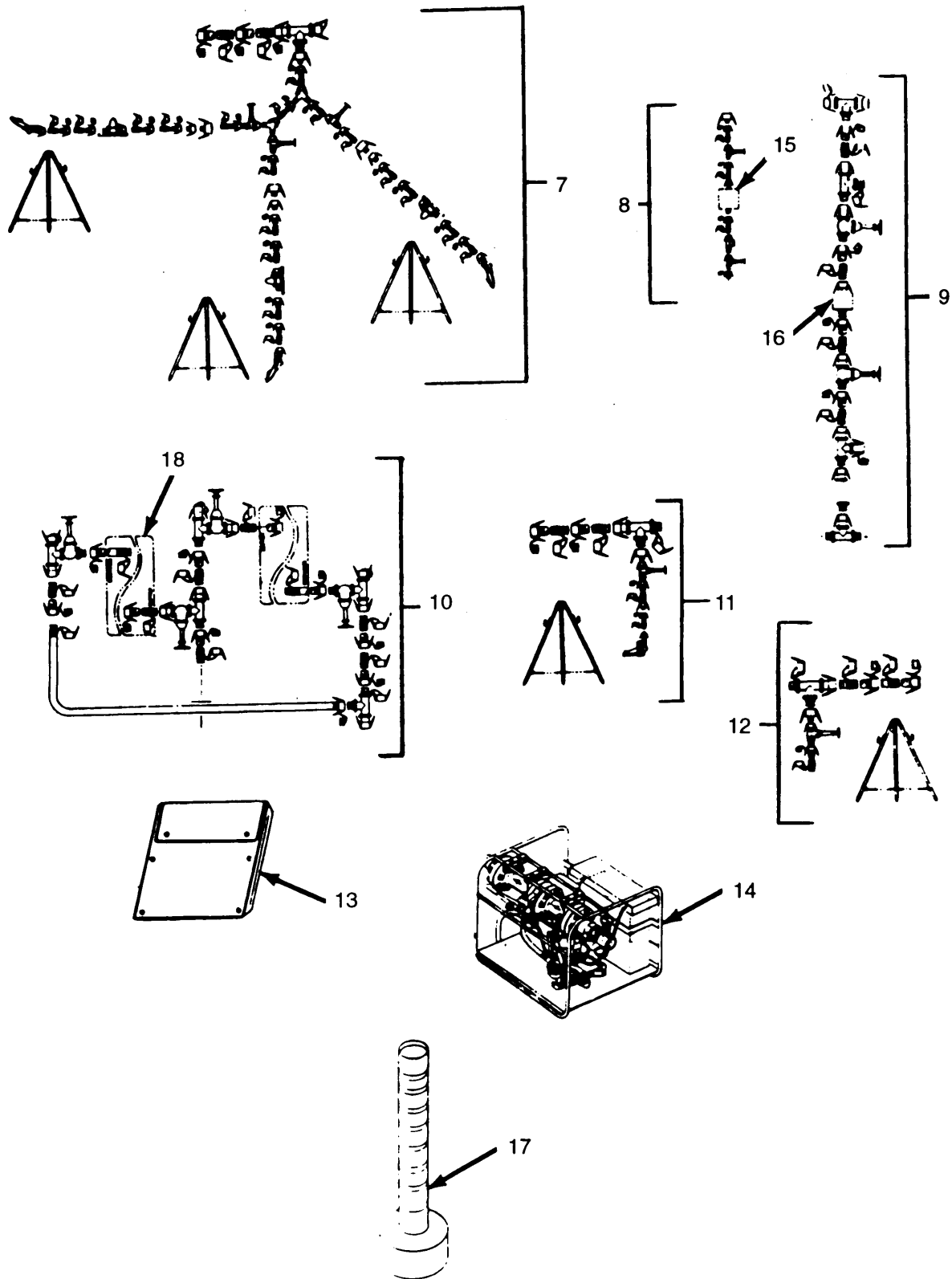

Section III. BASIC ISSUE ITEMS

(1) Illus Number	(2) National Stock Number	(3) Description CAGEC and Part Number	Usable On Code	(4) U/I	(5) Qty rqr
1		TECHNICAL MANUAL, OPERATOR'S UNIT AND DIRECT SUPPORT MAINTENANCE FOR 40,000 GALLON WATER DISTRIBUTION SYSTEM, TM 10-4610-234-13.		EA	1

TM 10-4610-234-13

TECHNICAL MANUAL

**OPERATOR'S, UNIT, AND DIRECT
SUPPORT MAINTENANCE MANUAL
FOR
40,000 GALLON WATER DISTRIBUTION
SYSTEM
NSN 4610-01-114-1451**

HOW TO USE THIS MANUAL	iii
EQUIPMENT DESCRIPTION	i
OPERATION UNDER USUAL CONDITIONS	2-1
UNIT MAINTENANCE PROCEDURES	2-1
DIRECT SUPPORT MAINTENANCE PROCEDURES	2-1
ALPHABETICAL INDEX	1-1

HEADQUARTERS, DEPARTMENT OF THE ARMY

**APPENDIX D
EXPENDABLE/DURABLE SUPPLIES AND MATERIALS LIST**

Section 1. INTRODUCTION

D.1 SCOPE.

This appendix lists expendable/durable supplies and materials you will need to operate and maintain the 40K Water Distribution System. These items are authorized to you by CTA 50-970, Expendable/Durable Items (except Medical, Class V, Repair Parts and Heraldic Items), or CTA 8-100, Army Medical Department Expendable/Durable Items.

D.2 D-2. EXPLANATION OF COLUMNS.

- a. Column 1- Item Number. This number is assigned to the entry in the listing and is referenced in the narrative instructions to identify the material (e.g., "Use wiping rag, Item 12, Appendix D").
- b. Column 2-Category. This column identified the lowest category of maintenance that required the listed item:
 - C - Operator/Crew
 - O - Unit Maintenance
 - F - Direct Support Maintenance
- c. Column 3- National Stock Number. This is the national stock number assigned to the item; use it to request or requisition the items.
- d. Column 4- Description. Indicates the federal item name and, if required, a description to identify the item. The last line for each item indicates the part number followed by the Commercial And Government Entity (CAGE) code in parentheses, if applicable.
- e. Column 5- Unit of Measure (U/M). Indicates the measure used in performing the actual maintenance function. This measure is expressed by a two character alphabetical abbreviation (e.g., ea, in, pr). If the unit of measure differs from the rest of the issue, requisition the lowest unit of issue that will satisfy your requirements.

Section II. EXPENDABLE/DURABLE SUPPLIES AND MATERIALS LIST

(1) ITEM NO.	(2) LEVEL	(3) NATIONAL STOCK NUMBER	(4) DESCRIPTION	(5) U/M
1	O	7930-00-985-6911	DETERGENT, GENERAL PURPOSE (81349) MIL-D-16791	5GL
2	O	7920-00-205-1711	RAG, WIPING (58536) A-A-531	BL
3	O	8030-00-889-3535	TAPE, ANTI-SEIZE (80244) MIL-T-27730 SZ2	RL

**APPENDIX E
ADDITIONAL AUTHORIZATION LIST (AAL)**

NOT APPLICABLE

NUMBERS

125 GPM Connection Kit Maintenance, 4-36.4
 125 GPM Pumping Assembly Maintenance,
 4-41
 20,000 Gallon Collapsible Fabric Tank
 Maintenance, 4-44
 350 GPM Pump Connection Kit Maintenance,
 4-27
 350 GPM Pumping Assembly Maintenance,
 4-36.4

A

Abbreviations, List of, 1-3
 Accessory Kit Maintenance, 4-44
 Additional Authorization List, E-1
 Adjustments, Initial, 2-17
 Assembly and Preparation for Use, 2-19
 Authorization List, Additional, E-1

B

Bag Filler Connection Kit Maintenance, 4-9
 Basic Issue Items, C-1

c

Capabilities and Features, Equipment
 Characteristics, 1-3
 Care and Handling, Safety, 1-7
 Characteristics, Capabilities, and Features,
 Equipment, 1-3
 Check Valve Assembly Maintenance, 4-37,
 4-40.1
 Checking Unpacked Equipment, 4-4
 Cold, Operation in Extreme, 2-40
 Collapsible Fabric Tank Maintenance, 20,000
 Gallon, 4-44
 Common Tools and Equipment, 4-1
 Component Maintenance, Water System, 3-4
 Component of End Item (COEI) and Basic
 Issue Items (BI) List, C-1
 Components, Location and Description of
 System, 1-3

INDEX

Connection Kit Maintenance
 120 GPM Pump, 4-36
 350 GPM Pump, 4-27
 Bag Filler, 4-9
 Dual Tank, 4-41
 Hose (2-inch), 4-27
 Couplings, Quick Disconnect, 2-17
 Cross Reference List, Nomenclature, 1-1

D

Data, Equipment, 1-6
 Decals and Instruction Plates, 2-38
 Description and Use of Operator's Controls and
 Indicators, Introduction, 2-1
 Description of System Components, Location and, 1-
 3
 Destruction of Army Materiel to Prevent Enemy Use,
 1-1
 Direct Support Maintenance Instructions, General, 5-1
 Discharge and Suction Hose Assembly Maintenance,
 4-10
 Disconnect Couplings, Quick, 2-17
 Distribution Nozzle (1-1/2 inch) Assembly
 Maintenance, 4-27
 Distribution Nozzle (1-1/2 inch) Repair, 5-14
 Distribution Nozzle (1-inch) Assembly Maintenance,
 4-22
 Distribution Nozzle (1-inch) Repair, 5-1
 Distribution Nozzles, 2-3
 Dual Tank Connection Kit Maintenance, 4-41
 Durable Supplies and Materials List, Expendable/, D-1
 Dusty or Sandy Areas, Operation in, 2-40

E

End Item, Components of, C-1
 Enemy Use, Destruction of Army Materiel to Prevent,
 1-1
 Equipment Characteristics, Capabilities, and
 Features, 1-3
 Equipment Data, 1-6

INDEX - continued.

Equipment Improvement Recommendations, Reporting, 1-1
 Equipment, Checking Unpacked, 4-4
 Equipment, Common Tools and, 4-1
 Expendable/Durable Supplies and Materials List, D-1
 Extreme Cold, Operation in, 2-40
 Extreme Heat, Operation in, 2-40

F

Fabric Tank Maintenance, 20,000 Gallon Collapsible, 4-44
 Features, Equipment Characteristics, Capabilities and, 1-3

G

Gate Valve Assembly (2-inch) Maintenance, 4-15, 4-17.1
 Gate Valve Assembly (4-inch) Maintenance, 4-28
 Gate Valves, 2-2
 General, 1-6, 2-17, 4-9, 5-1
 General Information, Scope, 1-1

H

Handling, Safety Care and, 1-7
 Heat, Operation in Extreme, 2-40
 Hose Assembly Maintenance, Discharge and Suction, 4-10
 Hose Connection Kit (2-inch) Maintenance, 4-27
 Hose Nozzle Kit Maintenance, 4-27
 How to Use this Manual, iii
 Hypochlorination Unit Maintenance, 4-27

I

Improvement Recommendations, Equipment Reporting, 1-1
 Initial Adjustments, 2-17
 Instruction Plates, Decals and, 2-38

Introduction, 2-1, 2-5, 3-1, 4-1, 4-6
 Issue Items, Basic, C-1

L

List of Abbreviations, 1-3
 List, Nomenclature Cross Reference, 1-1
 Location and Description of System Components, 1-3

M

Maintenance

125 GPM Connection Kit, 4-36.4
 125 GPM Pumping Assembly, 4-41
 20,000 Gallon Collapsible Fabric Tank, 4-44
 350 GPM Pump Connection Kit, 4-27
 350 GPM Pumping Assembly, 4-36.4
 Accessory Kit, 4-44
 Bag Filler Connection Kit, 4-9
 Check Valve Assembly, 4-37,4-40.1
 Discharge and Suction Hose Assembly, 4-10
 Distribution Nozzle (1-1/2 inch) Assembly, 4-27
 Distribution Nozzle, (1-inch) Assembly, 4-22
 Dual Tank Connection Kit, 4-41
 Gate Valve Assembly (2-inch), 4-15, 4-17.1
 Gate Valve Assembly (4-inch), 4-28
 Gate Valve Assembly, Tee and, 4-42
 Hose Connection Kit (2-inch), 4-27
 Hose Nozzle Kit, 4-27
 Hypochlorination Unit, 4-27
 Nozzle Stand Assembly, 4-25
 Tee and Gate Valve, 4-42
 Tee Assembly, 4-18
 Water Meter Assembly (Model WSDS40K), 4-32
 Water Meter Assembly (Model 40KWSDS), 4-36
 Water Pressure Regulator Assembly, 4-32
 Water System Components, 3-4
 Water Tank Chest, 4-45

Maintenance Allocation Chart, B-1
 Maintenance Forms and Records, 1-1
 Materials List, Expendable/Durable, Supplies and, D-1
 Meter, Water, 2-4
 Movement, Preparation for, 2-37

INDEX - continued.

N

Nomenclature Cross Reference List, 1-1
 Nozzle (1-1/2 inch) Assembly Maintenance, Distribution, 4-27
 Nozzle (1-1/2 inch) Repair, Distribution, 5-14
 Nozzle (1-inch) Assembly Maintenance, Distribution, 4-22
 Nozzle (1-inch) Repair, Distribution, 5-1
 Nozzle Kit Maintenance, Hose, 4-27
 Nozzle Stand Assembly Maintenance, 4-25
 Nozzles, Distribution, 2-3

O

Operations, 4-25
 Operations in
 Dusty or Sandy Areas, 2-40
 Extreme Cold, 2-40
 Extreme Heat, 2-40
 Operation Under Usual Conditions, General, 2-17
 Operation, Technical Principles of, 1-6
 Operator, Troubleshooting, 3-1
 Operator PMCS, 2-6
 Introduction, 2-5
 Operator Troubleshooting Procedures, Introduction, 3-1

P

Plates, Decals and Instructions, 2-38
 Preparation for Movement, 2-37
 Preparation for Storage or Shipment, 1-1
 Preparation for Use, Assembly and, 2-19
 Prevent Enemy Use, Destruction of Army Material to, 1-1
 Preventive Maintenance Checks and Services (PMCS)
 Operator, 2-6
 Unit, 4-4
 Principles of Operation, Technical, 1-6
 Pump Connection Kit Maintenance, 350 GPM, 4-27

Pumping Assembly Maintenance

125 GPM, 4-41
 350 GPM, 4-36.4

Q

Quick Disconnect Couplings, 2-17

R

Recommendations, Equipment Improvement Reporting, 1-1
 Records, Maintenance Forms and, 1-1
 Reference List, Nomenclature Cross, 1-1
 References, A-1
 Regulator Assembly Maintenance, Water Pressure, 4-23
 Regulator Repair, Water Pressure, 5-6
 Removing Equipment from Service, 4-52
 Repair
 Distribution Nozzle (1-1/2 inch), 5-14
 Distribution Nozzle (1-inch), 5-1
 Water Pressure Regulator, 5-6
 Water Tank Chest, 5-18
 Repair Parts, Unit, 4-1
 Reporting Equipment Improvement Recommendations (EIR's), 1-1

S

Safety Care and Handling, 1-7
 Sandy Areas, Operation in Dusty or, 2-40
 Scope, 1-1
 Selection, Site, 4-1
 Service Upon Receipt, Introduction, 4-1
 Shipment, Preparation for Storage or, 1-1
 Site Selection, 4-1
 Special Tools, Unit, 4-1
 Special Tools, TMDE, and Support Equipment, 4-1
 Stand Assembly Maintenance, Nozzle, 4-25
 Storage, 4-52
 Storage or Shipment, Preparation for, 1-1

INDEX - continued.

Suction Hose Assembly Maintenance,
Discharge and, 4-10
Supplies and Materials List,
Expendable/Durable, D-1
Support Equipment, Unit, 4-1
System Component Maintenance, Water, 3-4
System Components, Location and
Description, 1-3

T

Tank Chest Maintenance, Water, 4-45
Tank Chest Repair, Water, 5-18
Tank Maintenance, 20,000 Gallon Collapsible
fabric, 4-44
Technical Principles of Operation, 1-6
 General, 1-6
Tee and Gate Valve Assembly Maintenance,
4-42
Tee Assembly Maintenance, 4-18
TMDE, Unit, 4-1
Tools and Equipment, Common, 4-1
Troubleshooting
 Operator, 3-1
 Unit, 4-6

U

Unit, Troubleshooting, 4-6
Unit Maintenance Procedures, General, 4-9
Unit PMCS, 4-4
Unit Troubleshooting Procedures, Introduction,
4-6
Unpacked Equipment, Checking, 4-4
Unpacking, 2-17, 4-1
Use, Assembly and Preparation for, 2-19

V

Valve Assembly Maintenance
Check, 4-37, 4-40.1
Gate (2-inch), 4-15, 4-17.1
Tee and Gate, 4-42

W

Warning Page, a
Water Meter, 2-4
Water Meter Assembly Maintenance (Model
WSDS40K), 4-32
Water Meter Assembly Maintenance (Model
40KWSDS), 4-36
Water pressure Regulator Assembly Maintenance,
4-23
Water Pressure Regulator Assembly Repair, 5-6
Water System Component Maintenance, 3-4
Water Tank Chest Maintenance, 4-45
Water Tank Chest Repair, 5-18

By Order of the Secretary of the Army:

Official

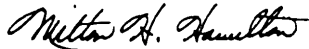

MILTON H. HAMILTON

*Administrative Assistant to the
Secretary of the Army*

04363

GORDON R. SULLIVAN
*General, United States Army
Chief of Staff*

DISTRIBUTION :

To be distributed in accordance with DA Form 12-25-E, block no. 6064,
requirements for TM 10-4610-234-13.

RECOMMENDED CHANGES TO EQUIPMENT TECHNICAL PUBLICATIONS



THEN... JOT DOWN THE DOPE ABOUT IT ON THIS FORM. CAREFULLY TEAR IT OUT, FOLD IT AND DROP IT IN THE MAIL!

SOMETHING WRONG WITH THIS PUBLICATION?

FROM (PRINT YOUR UNIT'S COMPLETE ADDRESS)
 CDR, 1st Br, 65th ADA
 ATTN: SP4 J. Brown
 Key West, FL 33040

DATE SENT
 10 Jun 79

PUBLICATION NUMBER
 TM 9-1430-550-34-1

PUBLICATION DATE
 7 Sep 72 .

PUBLICATION TITLE Unit of Radar Set
 AN/MPQ-50 Tested at the HFC

BE EXACT PIN-POINT WHERE IT IS

PAGE NO	PARA. GRAPH	FIGURE NO	TABLE NO
9-19		9-5	
21-2	step 1C	21-2	

IN THIS SPACE TELL WHAT IS WRONG AND WHAT SHOULD BE DONE ABOUT IT:

"B" Ready Relay K11 is shown with two #9 contacts. That contact which is wired to pin 8 of relay K16 should be changed to contact #10.

Reads: Multimeter B indicates 600 K ohms to 9000 K ohms.

Change to read: Multimeter B indicates 600 K ohms minimum.

Reason. Circuit being checked could measure infinity. Multimeter can read above 9000 K ohms and still be correct.

SAMPLE

PRINTED NAME GRADE OR TITLE AND TELEPHONE NUMBER

SP4 J.T. Brown, Jr.

SIGN HERE

SP4 James Brown, Jr.

TEAR ALONG PERFORATED LINE

FILL IN YOUR
UNITS ADDRESS



FOLD BACK

DEPARTMENT OF THE ARMY



OFFICIAL BUSINESS

COMMANDER
U.S. ARMY AVIATION AND TROOP COMMAND
ATTN: AMSAT-I-MP
4300 GOODFELLOW BOULEVARD
ST. LOUIS, MO 63120-1798

TEAR ALONG PERFORATED LINE

1 Nov 80

FILL IN YOUR
UNITS ADDRESS



FOLD BACK

DEPARTMENT OF THE ARMY

OFFICIAL BUSINESS

COMMANDER
U.S. ARMY AVIATION AND TROOP COMMAND
ATTN: AMSAT-I-MP
4300 GOODFELLOW BOULEVARD
ST. LOUIS, MO 63120-1798

TEAR ALONG PERFORATED LINE

RECOMMENDED CHANGES TO EQUIPMENT TECHNICAL PUBLICATIONS



THEN... JOT DOWN THE DOPE ABOUT IT ON THIS FORM. CAREFULLY TEAR IT OUT. FOLD IT AND DROP IT IN THE MAIL.

SOMETHING WRONG WITH THIS PUBLICATION?

FROM (PRINT YOUR UNIT'S COMPLETE ADDRESS)

DATE SENT

PUBLICATION NUMBER

TM 10-4610-234-13

PUBLICATION DATE

30 June 1993

PUBLICATION TITLE

40,000 GALLON WATER DISTRIBUTION SYSTEM

BE EXACT PIN-POINT WHERE IT IS

PAGE NO

PARA-GRAPH

FIGURE NO

TABLE NO

IN THIS SPACE TELL WHAT IS WRONG AND WHAT SHOULD BE DONE ABOUT IT:

PRINTED NAME GRADE OR TITLE AND TELEPHONE NUMBER

SIGN HERE

FILL IN YOUR
UNITS ADDRESS



FOLD BACK

DEPARTMENT OF THE ARMY

OFFICIAL BUSINESS

COMMANDER
U.S. ARMY AVIATION AND TROOP COMMAND
ATTN: AMSAT-I-MP
4300 GOODFELLOW BOULEVARD
ST. LOUIS, MO 63120-1798

TEAR ALONG PERFORATED LINE

RECOMMENDED CHANGES TO EQUIPMENT TECHNICAL PUBLICATIONS



THEN... JOT DOWN THE DOPE ABOUT IT ON THIS FORM. CAREFULLY TEAR IT OUT. FOLD IT AND DROP IT IN THE MAIL!

SOMETHING WRONG WITH THIS PUBLICATION?

FROM (PRINT YOUR UNIT'S COMPLETE ADDRESS)

DATE SENT

PUBLICATION NUMBER
TM 10-4610-234-13

PUBLICATION DATE
30 June 1993

PUBLICATION TITLE
40,000 GALLON WATER DISTRIBUTION SYSTEM

BE EXACT PIN-POINT WHERE IT IS

PAGE NO

PARA-GRAPH

FIGURE NO

TABLE NO

IN THIS SPACE TELL WHAT IS WRONG AND WHAT SHOULD BE DONE ABOUT IT:

PRINTED NAME GRADE OR TITLE AND TELEPHONE NUMBER

SIGN HERE

1 Nov 80

FILL IN YOUR
UNITS ADDRESS



FOLD BACK

DEPARTMENT OF THE ARMY

OFFICIAL BUSINESS

COMMANDER
U.S. ARMY AVIATION AND TROOP COMMAND
ATTN: AMSAT-I-MP
4300 GOODFELLOW BOULEVARD
ST. LOUIS, MO 63120-1798

TEAR ALONG PERFORATED LINE

The Metric System and Equivalents

Linear Measure

1 centimeter = 10 millimeters = .39 inch
 1 decimeter = 10 centimeters = 3.94 inches
 1 meter = 10 decimeters = 39.37 inches
 1 dekameter = 10 meters = 32.8 feet
 1 hectometer = 10 dekameters = 328.08 feet
 1 kilometer = 10 hectometers = 3,280.8 feet

Weights

1 centigram = 10 milligrams = .15 grain
 1 decigram = 10 centigrams = 1.54 grains
 1 gram = 10 decigram = .035 ounce
 1 dekagram = 10 grams = .35 ounce
 1 hectogram = 10 dekagrams = 3.52 ounces
 1 kilogram = 10 hectograms = 2.2 pounds
 1 quintal = 100 kilograms = 220.46 pounds
 1 metric ton = 10 quintals = 1.1 short tons

Liquid Measure

1 centiliter = 10 milliliters = .34 fl. ounce
 1 deciliter = 10 centiliters = 3.38 fl. ounces
 1 liter = 10 deciliters = 33.81 fl. ounces
 1 dekaliter = 10 liters = 2.64 gallons
 1 hectoliter = 10 dekaliters = 26.42 gallons
 1 kiloliter = 10 hectoliters = 264.18 gallons

Square Measure

1 sq. centimeter = 100 sq. millimeters = .155 sq. inch
 1 sq. decimeter = 100 sq. centimeters = 15.5 sq. inches
 1 sq. meter (centare) = 100 sq. decimeters = 10.76 sq. feet
 1 sq. dekameter (are) = 100 sq. meters = 1,076.4 sq. feet
 1 sq. hectometer (hectare) = 100 sq. dekameters = 2.47 acres
 1 sq. kilometer = 100 sq. hectometers = .386 sq. mile -

Cubic Measure

1 cu. centimeter = 1000 cu. millimeters = .06 cu. inch
 1 cu. decimeter = 1000 cu. centimeters = 61.02 cu. inches
 1 cu. meter = 1000 cu. decimeters = 35.31 cu. feet

Approximate Conversion Factors

To change	To	Multiply by	To change	To	Multiply by
inches	centimeters	2.540	ounce-inches	newton-meters	.007062
feet	meters	.305	centimeters	inches	.394
yards	meters	.914	meters	feet	3.280
miles	kilometers	1.609	meters	yards	1.094
square inches	square centimeters	6.451	kilometers	miles	.621
square feet	square meters	.093	square centimeters	square inches	.155
square yards	square meters	.836	square meters	square feet	10.764
square miles	square kilometers	2.590	square meters	square yards	1.196
acres	square hectometers	.405	square kilometers	square miles	.386
cubic feet	cubic meters	.028	square hectometers	acres	2.471
cubic yards	cubic meters	.765	cubic meters	cubic feet	35.315
fluid ounces	milliliters	29.573	cubic meters	cubic yards	1.308
pints	liters	.473	milliliters	fluid ounces	.034
quarts	liters	.946	liters	pints	2.113
gallons	liters	3.785	liters	quarts	1.057
ounces	grams	28.349	liters	gallons	.264
pounds	kilograms	.454	grams	ounces	.035
short tons	metric tons	.907	kilograms	pounds	2.205
pound-feet	newton-meters	1.356	metric tons	short tons	1.102
pound-inches	newton-meters	.11296			

Temperature (Exact)

°F	Fahrenheit temperature	5/9 (after subtracting 32)	Celsius temperature	°C
----	------------------------	----------------------------	---------------------	----

PIN: 071423-002